



CONTACTRON Speed Starter

User manual

User manual

CONTACTRON Speed Starter

UM EN CONTACTRON Speed Starter, Revision 00

2021-09-02

This user manual is valid for:

Designation	Order No.
CSS 0.25-1/3	1201132
CSS 0.37-1/3	1201135
CSS 0.55-1/3	1201494
CSS 0.75-1/3	1201509
CSS 1.5-1/3	1201511
CSS 0.25-1/3-EMC	1201520
CSS 0.37-1/3-EMC	1201600
CSS 0.55-1/3-EMC	1201602
CSS 0.75-1/3-EMC	1201613
CSS 1.5-1/3-EMC	1201642
CSS 0.25-3/3	1201679
CSS 0.37-3/3	1201683
CSS 0.55-3/3	1201694
CSS 0.75-3/3	1201695
CSS 1.5-3/3	1201650
CSS 0.25-3/3-EMC	1201713
CSS 0.37-3/3-EMC	1201825
CSS 0.55-3/3-EMC	1201828
CSS 0.75-3/3-EMC	1201829
CSS 1.5-3/3-EMC	1201696
EM-CSS-FAN-35	1276911
EM-CSS-FAN-45	1276912
EM-CSS-MOTORSHIELD-35	1276914
EM-CSS-MOTORSHIELD-45	1276916
EM-CSS-CONTROLSHIELD-35	1276904

109908_en_00

2021-09-02

Designation
EM-CSS-CONTROLSHIELD-45

Order No.
1276909

109908_en_00

2021-09-02

109908_en_00

Table of contents

1	For your safety	9
	1.1 Labeling of warning notes	9
	1.2 Qualification of users	9
	1.3 Field of application of the product	10
	1.3.1 Intended use	10
	1.3.2 Foreseeable misuse	10
	1.3.3 Product changes	10
	1.3.4 After unpacking	10
	1.4 Safety notes	11
2	Introduction	15
	2.1 Model overview	15
	2.2 Nameplate information (example)	16
	2.3 Model name	17
3	Dimensions	19
	3.1 Frame A1	19
	3.2 Frame A2	20
	3.3 Frame B1 with fan	21
	3.4 Frame B1 with heat sink	22
	3.5 Frame B2	23
4	Installation	25
	4.1 Mounting clearances	25
	4.2 DIN Rail mounting.....	29
	4.2.1 Installing the CONTACTRON Speed Starter onto the DIN rail	29
	4.2.2 Removing the CONTACTRON Speed Starter from the DIN rail	30
5	Wiring	31
	5.1 Power terminals.....	31
	5.2 Control terminals	32
	5.2.1 Wiring precautions	33
	5.2.2 PE terminal	34
	5.3 Wiring diagram	35
	5.4 Connection possibilities	36
	5.5 IT jumper	38
	5.5.1 Removal	39
	5.5.2 Mains types	41

5.6	Motor cable length	44
5.6.1	Consequence of leakage current	44
5.6.2	Consequence of the surge voltage	44
6	Main circuit diagram	47
7	Standard fuses and circuit breakers	49
7.1	Standard fuses (for IEC)	49
7.2	Standard fuses and circuit breakers (for UL and cUL)	50
7.2.1	Branch circuit protection with standard fuses	50
7.2.2	Branch circuit protection with circuit breakers	52
8	Accessories and spare parts	53
8.1	EMC shielding plate	53
8.1.1	Installation	55
8.2	Fan kit	58
8.2.1	Fan removal	60
8.2.2	Fan installation	60
9	Control panel	61
9.1	Panel	61
9.2	Control panel operation process.....	63
9.2.1	Rotary switch in "CURRENT" position	63
9.2.2	Rotary switch in "RAMP" position	64
9.2.3	Rotary switch in "STATUS" position	65
9.2.4	Rotary switch in "SPEED1" / "SPEED2" position when STOP	66
9.2.5	Rotary switch in "SPEED1" / "SPEED2" when RUNNING	67
9.2.6	Rotary switch in "SPEED1" or "SPEED2" position for direction setting at STOP	68
9.2.7	Rotary switch in "OPTIONS" position	69
9.3	Status summary.....	72
10	Description of parameter settings	73
10.1	Rotary switch in "CURRENT" position	73
10.2	Rotary switch in "RAMP" position	74
10.3	Rotary switch in "STATUS" position	75
10.4	Rotary switch in "SPEED1" or "SPEED2" position	76
10.4.1	SPEED1 frequency command	76
10.4.2	SPEED1 direction	76
10.4.3	SPEED2 frequency command	76
10.4.4	SPEED2 direction	76
10.5	Rotary switch in "OPTIONS" position	77

10.5.1	Motor rated frequency	77
10.5.2	Motor rated voltage	78
10.5.3	Highest output frequency	78
10.5.4	Pulse frequency	79
10.5.5	V/F-waveform	81
10.5.6	Start boost	81
10.5.7	Voltage lift	81
10.5.8	Slip compensation	82
10.5.9	PTC	83
10.5.10	Parameter lock	84
10.5.11	Parameter reset	84
10.5.12	Identity code	85
10.5.13	Firmware version	85
10.5.14	Relay output	85
11	Warning Codes	87
12	Error codes	91
13	STO - Safe Torque Off	103
13.1	Defined safety function	103
13.2	Safety information.....	104
13.3	STO input	104
13.4	Safety parameters	105
14	Application notes	107
14.1	Application examples without STO function	107
14.1.1	1-phase	107
14.1.2	3-phase	108
14.2	Application examples with STO function	109
14.3	Block diagram.....	112
14.3.1	1-phase	112
14.3.2	3-phase	113
A	Technical data	115
A 1	230 V models.....	115
A 2	480 V models.....	119
A 3	General specifications	123
A 4	Environment for operation, storage and transportation	125
A 5	Derating for altitude and carrier frequency.....	127
A 6	Operational limits.....	129
A 7	Applicable standards	130

B	Reference table for the seven-segment digital control panel LED display	131
C	Appendixes.....	133
	C 1 List of figures	133
	C 2 List of tables	137
	C 3 Explanation of terms.....	139
	C 4 Index.....	141

1 For your safety

Read this user manual carefully and keep it for future reference.

1.1 Labeling of warning notes



This symbol indicates hazards that could lead to personal injury.

There are three signal words indicating the severity of a potential injury.

DANGER

Indicates a hazard with a high risk level. If this hazardous situation is not avoided, it will result in death or serious injury.

WARNING

Indicates a hazard with a medium risk level. If this hazardous situation is not avoided, it could result in death or serious injury.

CAUTION

Indicates a hazard with a low risk level. If this hazardous situation is not avoided, it could result in minor or moderate injury.



This symbol together with the **NOTE** signal word alerts the reader to a situation which may cause damage or malfunction to the device, hardware/software, or surrounding property.



Here you will find additional information or detailed sources of information.

1.2 Qualification of users

The use of products described in this manual is oriented exclusively to electrically skilled persons or persons instructed by them. The users must be familiar with the relevant safety concepts of automation technology as well as applicable standards and other regulations.

1.3 Field of application of the product

1.3.1 Intended use

The CONTACTRON Speed Starter is a motor switching device to start, reverse and protect the asynchronous motor in case of an overload and switch off the motor in case of an emergency stop (STO). Additionally, a ramp for soft start/soft stop as well as different speeds can be set in the device. This device is only suitable for control cabinets.

1.3.2 Foreseeable misuse

- When operating a 1-phase device with 1-phase mains with at least 200 V AC, you must not set the motor voltage to 110 V AC in the OPTIONS menu. Otherwise, the device could be damaged.
- Do not connect a 1-phase device to three phases.
- Do not unmount the control panel while the device is connected to power.

1.3.3 Product changes

Changes or modifications to hardware and software of the device are not permitted.

- Incorrect operation or modifications to the device can endanger your safety or damage the device. Do not repair the device yourself. If the device is defective, please contact Phoenix Contact.

1.3.4 After unpacking

After receiving the CONTACTRON Speed Starter, check the following:

- Inspect the unit after unpacking to ensure that it was not damaged during shipment. Make sure that the part number printed on the package matches the part number indicated on the nameplate.
- Make sure that the mains voltage is within the range indicated on the nameplate. Install the CONTACTRON Speed Starter according to the instructions in this manual.
- Before applying power, make sure that all connections, for example mains voltage, the control wiring and the motor cables are connected correctly.
- When wiring the CONTACTRON Speed Starter, make sure that the wiring of input terminals "L1, L2, L3" and output terminals "U, V, W" are correct to prevent damage to the CONTACTRON Speed Starter.

1.4 Safety notes

**The "attention symbol" on the device label means:**

Read the safety and installation notes in their entirety.

Failure to follow the instructions may impair the safety features provided.

**The "high voltage symbol" on the device label means: Dangerous contact voltage**

Only qualified personnel may do this work. The personnel must be familiar with the necessary safety precautions.

Failure to follow the instructions may result in damage or injury.

**The "hot surfaces symbol" on the device label means:**

The surfaces of the device may get hot.

Use personal protective equipment or wait for cooling-off.

Failure to follow the instructions may result in damage or injury.

- Installation, operation, and maintenance may only be carried out by qualified electricians. Follow the installation instructions as described.
- When installing and operating the device, observe the applicable regulations and safety directives (including national safety directives), as well as general technical regulations.
- Install the device in accordance with the instructions described in the installation notes. Accessing circuits within the device is prohibited.
- Only clean the device with a suitable damp cloth. Do not use abrasive cleaners or aggressive solvents. Switch off the device before cleaning and disconnect the device from the power distribution.
- Ensure that all devices and adapters are attached and connected correctly to prevent the devices from being damaged.
- Refer to the documentation before installation.

**DANGER:**

- Turn off the CONTACTRON Speed Starter power before doing any wiring. A charge with hazardous voltages may remain in the DC link circuit capacitors even after the power has been turned off for a short time. For your safety, do not start wiring before the voltage drops to a safe level (less than 25 V DC). Installing wiring with a residual voltage may cause personal injury, sparks and a short circuit.
- Make sure that power is only applied to the L1, L2, and L3 terminals. Failure to comply may result in damage to the equipment. The voltage and current must be in the range indicated on the nameplate (refer to [2.2 "Nameplate information \(example\)"](#) for details).
- All units must be grounded directly to a common ground terminal to prevent damage from an electric arc or electric shock and reduce noise interference.

**CAUTION:**

- For your safety, choose wires that comply with local regulations when wiring.
- Check the following items after finishing the wiring:
 - Are all connections correct?
 - Are there any loose wires?
 - Are there any short circuits between the terminals or to ground?

**DANGER:**

- If necessary, only use an inductive filter at the motor output terminals U, V, W of the CONTACTRON Speed Starter. Do not use phase-compensation capacitors or I-C (Inductance-Capacitance) or R-C (Resistance-Capacitance).
- Do not connect surge absorbers at the output terminals of CONTACTRON Speed Starters.
- Ensure proper insulation of the main circuit wiring in accordance with the relevant safety regulations.

**CAUTION:****Input power terminals**

- Although the leakage current of one single CONTACTRON Speed Starter is 10 mA AC, electric shock may still occur due to the leakage current from other equipment such as motors and leads. Therefore, it is recommended that you install one of the followings to prevent danger caused by electric shock.
 - Use a copper wire with a cross-section of 10 mm² or connect 2x PE with at least outer conductor cross section.
 - Install an Earth Leakage Circuit Breaker (ELCB) or a residual current device (RCD).
- Due to the high frequency current of the leakage current of the CONTACTRON Speed Starter, select a Type B ELCB or RCD specifically for the CONTACTRON Speed Starter when using an ELCB. The power system of the CONTACTRON Speed Starter affects the power factor, so select a Molded Case Circuit Breaker (MCCB) with larger capacity.
- Use shielded wire or conduit for the power wiring and ground the two ends of the shielding or conduit.
- Do not run and stop the CONTACTRON Speed Starters by turning the power ON and OFF. Run and stop the CONTACTRON Speed Starters by sending the RUN and STOP commands to the control terminals. If you still need to run and stop the CONTACTRON Speed Starters by turning the power ON and OFF, do so no more often than once per hour.
- To comply with UL standards, connect the CONTACTRON Speed Starter to a three-phase three-wire or three-phase four-wire Wye system type of mains power system.
- For use in the IT-system, refer to ["IT jumper" on page 38](#).

Output terminals of the main circuit

- Use well-insulated motors to prevent any electric leakage from motors.
- When the CONTACTRON Speed Starter output terminals U, V, and W are connected to the motor terminals U, V, and W respectively, the "R" LED indicator on the digital control panel is ON. This means the CONTACTRON Speed Starter executes running forward, and the motor rotates clockwise (viewed from the shaft end of the motor).
- On the contrary, when the "L" LED indicator lights, the CONTACTRON Speed Starter executes running in reverse, and the motor rotates as shown in [Figure 1-1](#). If the CONTACTRON Speed Starter executes running forward but the motor rotates in a reverse direction, exchange any two of the U, V and W motor leads.

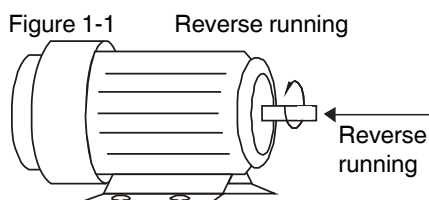

2 Introduction

The CONTACTRON Speed Starter, with particularly intuitive operation, is the device class between motor starters and frequency converters. This compact solution provides all of the functions necessary for different speeds, soft start, and safe stopping with the Safe Torque Off function.

The main advantages of this device are:

- Quick installation and startup with easy wiring and intuitive operation concept
- Safe shutdown with the integrated Safe Torque Off function (STO)
- Space savings in the control cabinet due to the compact design with an overall width starting at only 35 mm
- Cost-effective solution with all functions necessary for different speeds and soft start

2.1 Model overview

Figure 2-1 Model overview

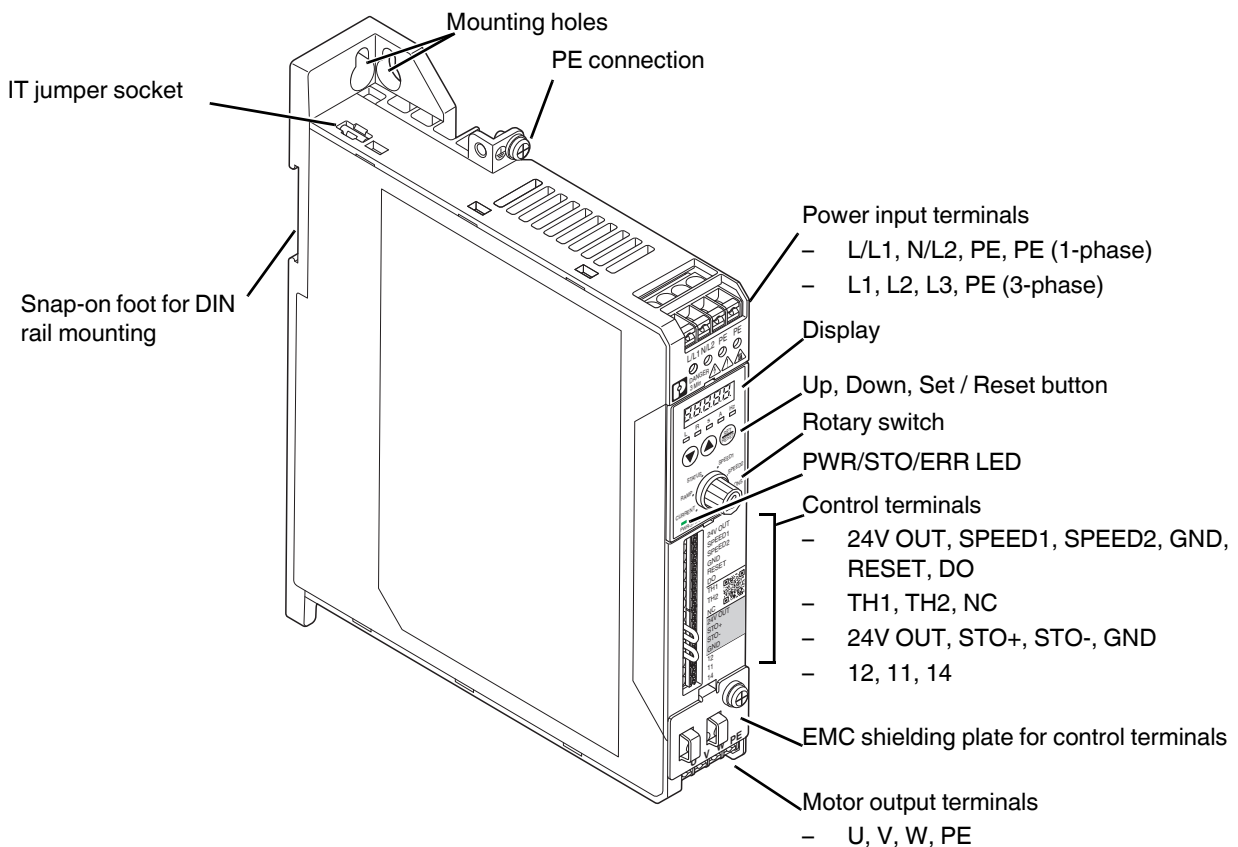



2.2 Nameplate information (example)

Figure 2-2 1-phase device

CSS 0.25-1/3
Order-No.:1201132

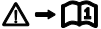
Documentation 

 

www.phoenixcontact.com
Version: 1.00





PHOENIX CONTACT GmbH & Co. KG
Flachsmarktstr. 8
32825 Blomberg, Germany

INPUT: 1PH 230/240V AC 50/60Hz 3.5A
(Range 1PH 110-240V AC via OPTIONS setting)
OUTPUT: 3PH 0-Input Voltage 1.7A 0.7KVA 0.25KW 0.3HP
FREQUENCY RANGE: 0-500Hz

IP20 Open-Type
NEMA 1  -20°C ... +55(+60)°C
-4°F ... +131(+140)°F
(+60)°C/(+140)°F with derating, see instruction manual



2105 

 Functional Safety Type Approved
www.tuv.com ID 0600000000

UK CA **IE2** 3.9%



 **LISTED**
IND. CONT. EQ
E322526

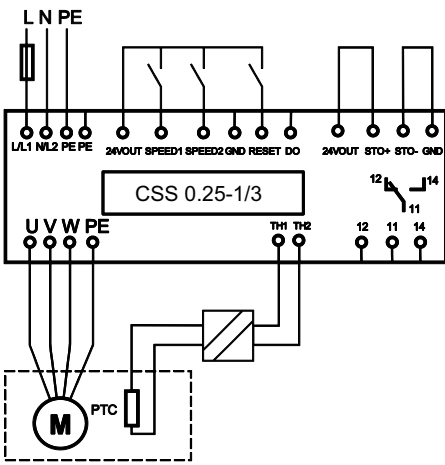

 **WARNING**
AVERTISSEMENT

- Read the user manual before operation.
- Risk of electrical shock. Wait 3 minutes after removing power before servicing.
- Do not connect AC power to output terminals U, V and W.

MADE BY PHOENIX CONTACT IN TAIWAN



Serial No.: CS025130T2105S001

- Lire le manuel avant de procéder à l'opération.
- Risque d'électrocution. Attendez au moins 3 minutes après la mise hors tension avant de procéder aux interventions.
- Ne pas brancher le câble d'alimentation en CA aux bornes de sortie U, V and W.

Scan the QR code for more information on the product page of the website.

16 / 146 PHOENIX CONTACT

109908_en_00

2.3 Model name

CSS 0.25 - 3/3 - EMC

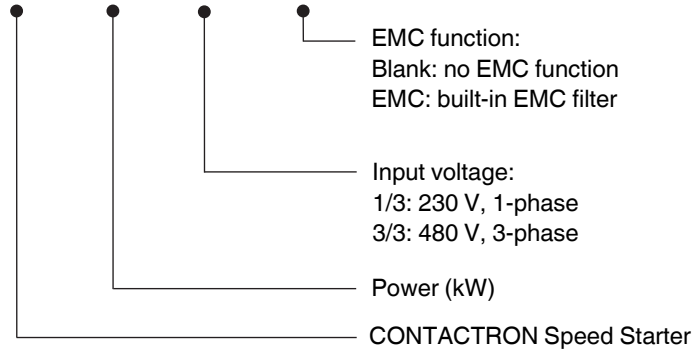

3 Dimensions

3.1 Frame A1

Figure 3-1 Frame A1: CSS 0.25-1/3, CSS 0.25-3/3, CSS 0.37-1/3, CSS 0.37-3/3, CSS 0.55-3/3

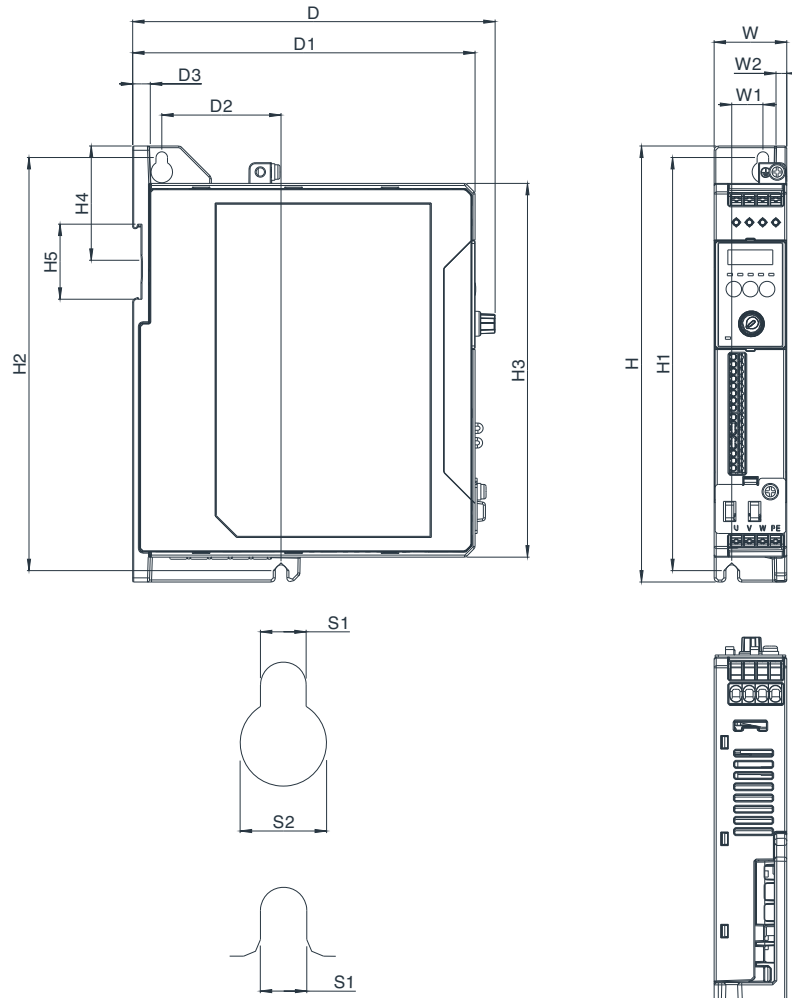

Table 3-1 Dimensions frame A1 (unit: mm [inch])

W	W1	W2	H	H1	H2	H3	H4
35.0 [1.38]	15.0 [0.59]	6.0 [0.24]	210.0 [8.27]	199.0 [7.83]	199.0 [7.83]	180 [7.09]	55.7 [2.19]
H5	D	D1	D2	D3	S1	S2	
36.2 [1.43]	174.7 [6.88]	165.0 [6.50]	57.5 [2.26]	8.5 [0.34]	5.5 [0.22]	10.4 [0.41]	

3.2 Frame A2

Figure 3-2 Frame A2: CSS 0.25-1/3-EMC, CSS 0.25-3/3-EMC, CSS 0.37-1/3-EMC, CSS 0.37-3/3-EMC, CSS 0.55-3/3-EMC, CSS 0.75-3/3-EMC

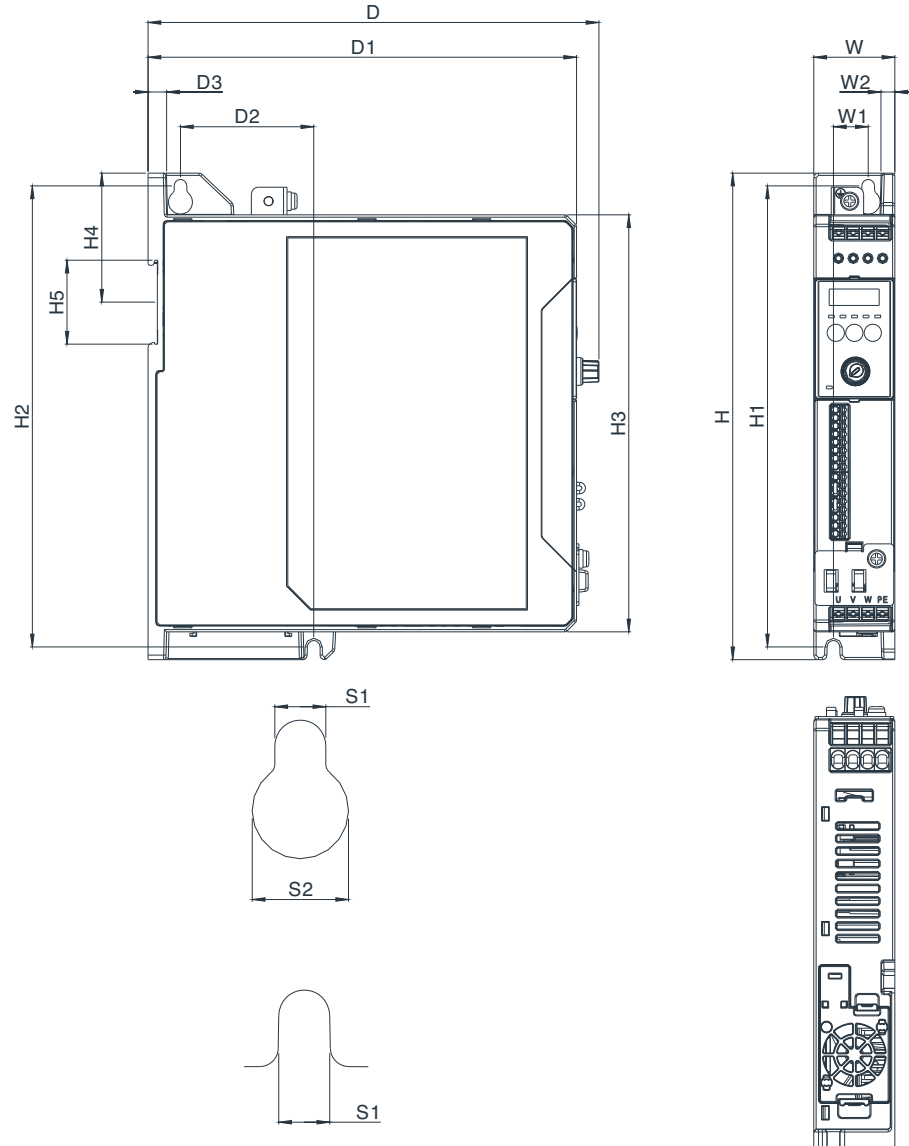

Table 3-2 Dimensions frame A2 (unit: mm [inch])

W	W1	W2	H	H1	H2	H3	H4
35.0 [1.38]	15.0 [0.59]	6.0 [0.24]	210.0 [8.27]	199.0 [7.83]	199.0 [7.83]	180 [7.09]	55.7 [2.19]
H5	D	D1	D2	D3	S1	S2	
36.2 [1.43]	194.7 [7.67]	185.0 [7.28]	57.5 [2.26]	8.0 [0.32]	5.5 [0.22]	10.4 [0.41]	

3.3 Frame B1 with fan

Figure 3-3 Frame B1: CSS 1.5-1/3, CSS 1.5-3/3

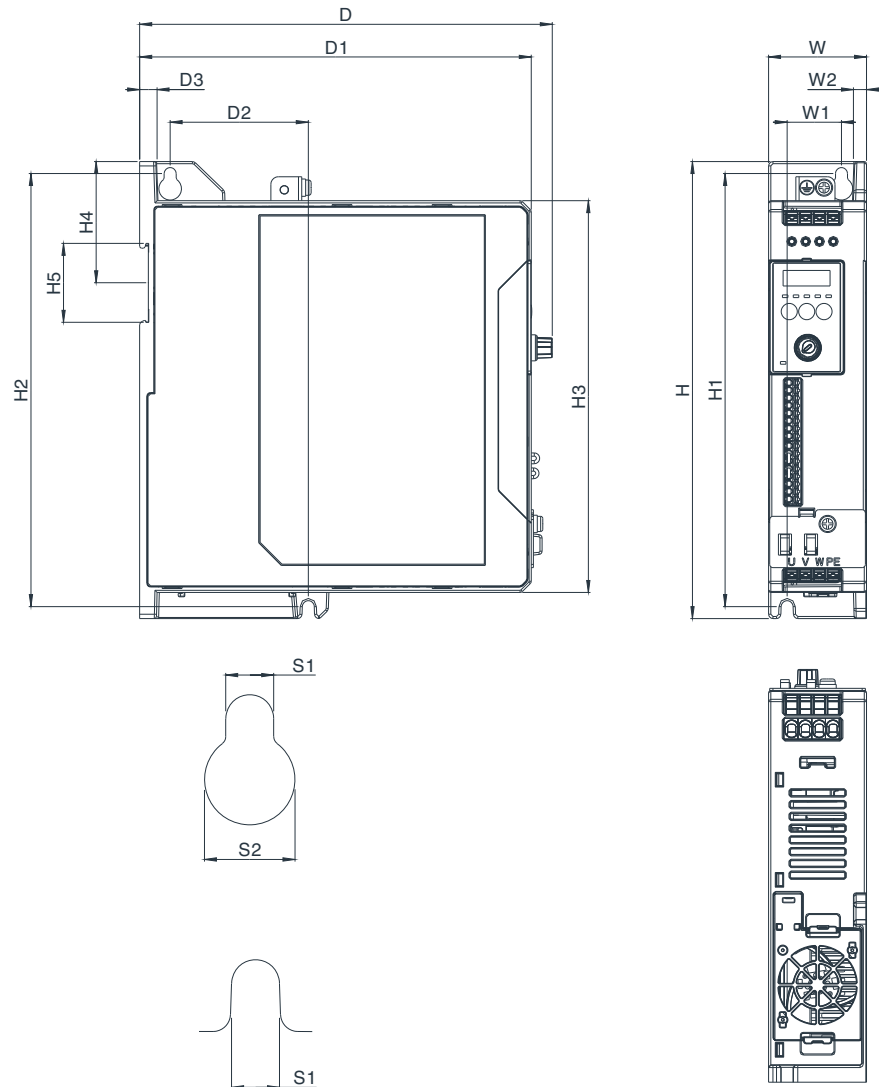

Table 3-3 Frame B1 with fan (unit: mm [inch])

W	W1	W2	H	H1	H2	H3	H4
45.0 [1.77]	25.0 [0.98]	6.0 [0.24]	210.0 [8.27]	199.0 [7.83]	199.0 [7.83]	180 [7.09]	55.7 [2.19]
H5	D	D1	D2	D3	S1	S2	
36.2 [1.43]	189.7 [7.47]	180.0 [7.09]	63.5 [2.50]	8.0 [0.32]	5.5 [0.22]	10.4 [0.41]	

3.4 Frame B1 with heat sink

Figure 3-4 Frame B1: CSS 0.55-1/3, CSS 0.75-1/3, CSS 0.75-3/3

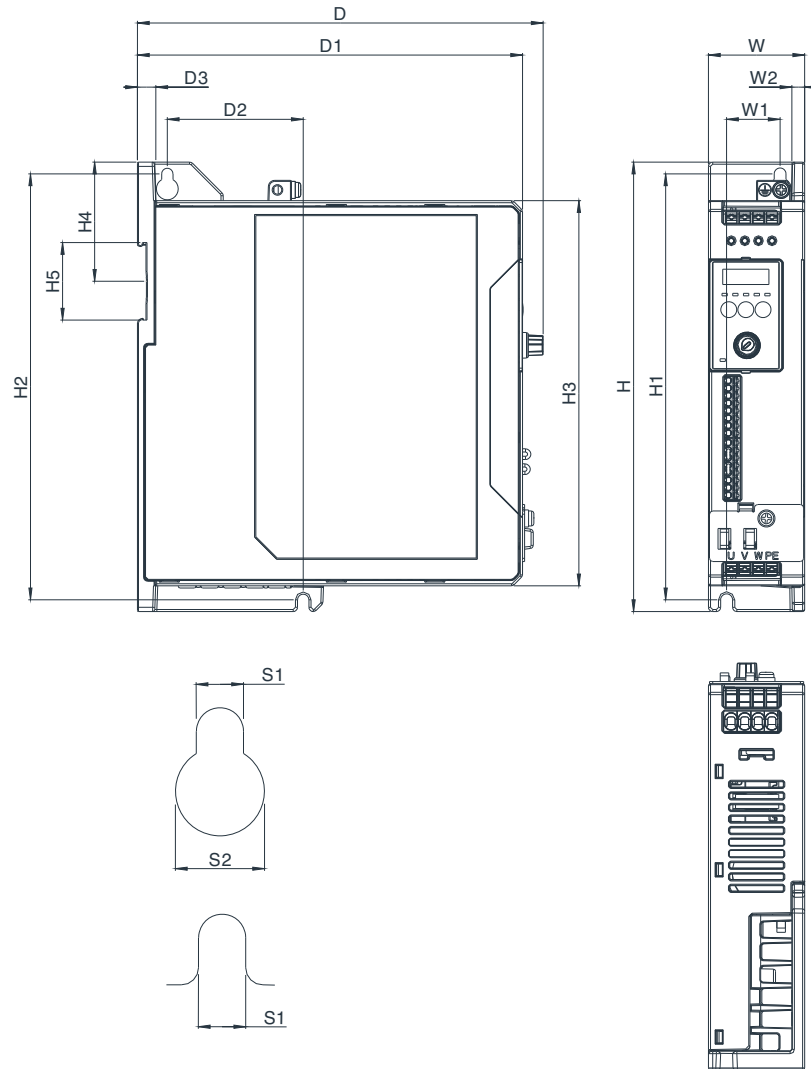

Table 3-4 Frame B1 with heat sink (unit: mm [inch])

W	W1	W2	H	H1	H2	H3	H4
45.0 [1.77]	25.0 [0.98]	6.0 [0.24]	210.0 [8.27]	199.0 [7.83]	199.0 [7.83]	180 [7.09]	55.7 [2.19]
H5	D	D1	D2	D3	S1	S2	
36.2 [1.43]	189.7 [7.47]	180.0 [7.09]	63.5 [2.50]	8.5 [0.34]	5.5 [0.22]	10.4 [0.41]	

3.5 Frame B2

Figure 3-5 Frame B2: CSS 0.55-1/3-EMC, CSS 0.75-1/3-EMC, CSS 1.5-1/3-EMC, CSS 1.5-3/3-EMC

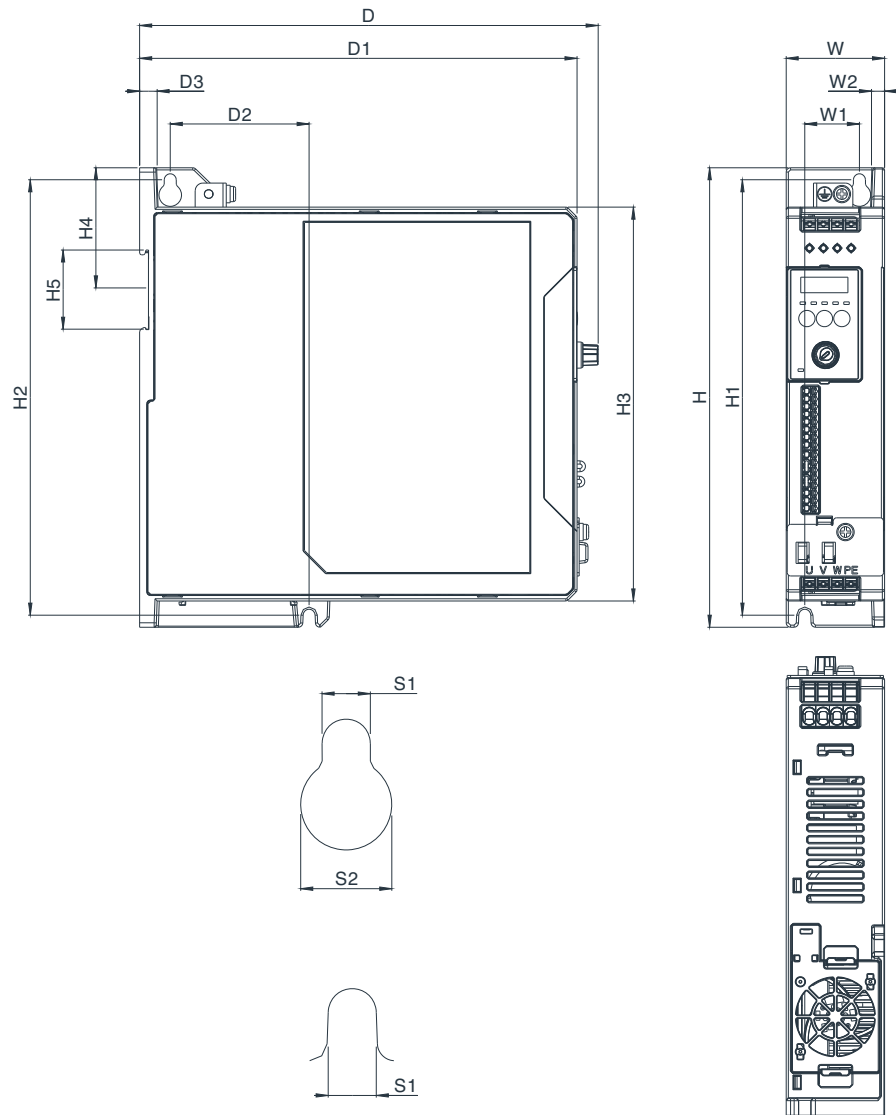

Table 3-5 Frame B2 (unit: mm [inch])

W	W1	W2	H	H1	H2	H3	H4
45.0 [1.77]	25.0 [0.98]	6.0 [0.24]	210.0 [8.27]	199.0 [7.83]	199.0 [7.83]	180 [7.09]	55.7 [2.19]
H5	D	D1	D2	D3	S1	S2	
36.2 [1.43]	209.7 [8.26]	200.0 [7.87]	63.5 [2.50]	8.0 [0.32]	5.5 [0.22]	10.4 [0.41]	

4 Installation

4.1 Mounting clearances

- Prevent fiber particles, scraps of paper, shredded wood, sawdust, metal particles, etc. from adhering to the heat sink.
- Install the CONTACTRON Speed Starter in a metal cabinet. When installing one CONTACTRON Speed Starter below another one, use a metal separator between the CONTACTRON Speed Starters to prevent mutual heating and to prevent the risk of fire accident.

Table 4-1 Airflow direction

Blue arrow	Inflow
Red arrow	Outflow
Black arrow	Distance

Figure 4-1 Airflow single installation

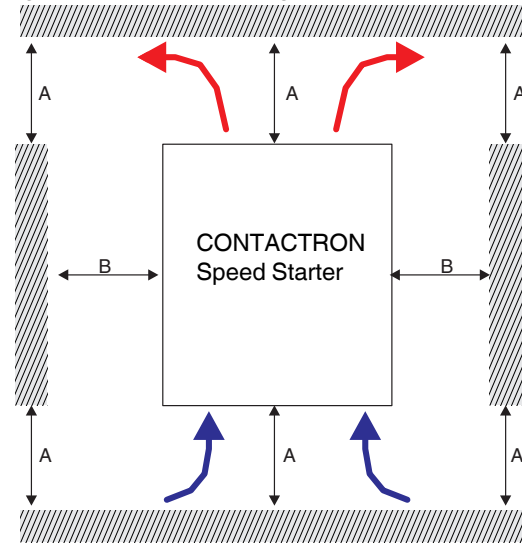

Figure 4-2 Airflow side-by-side horizontal installation / zero stacking installation / side-mounting installation

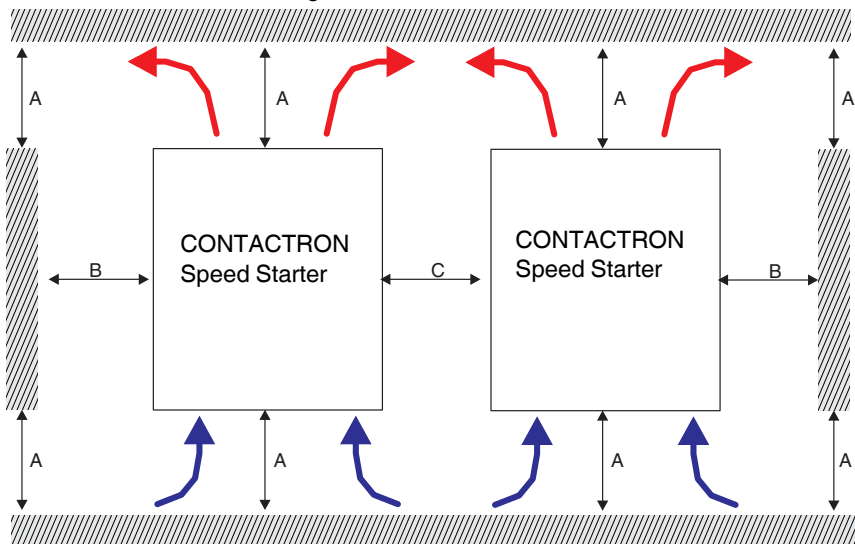
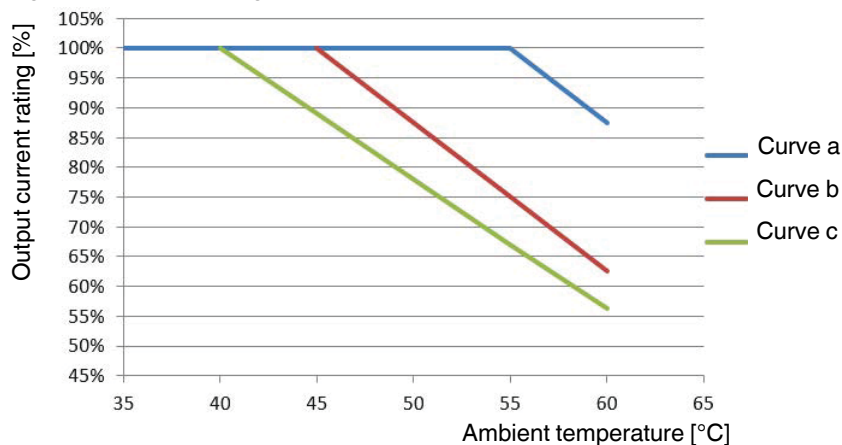

Table 4-2 Minimum mounting clearances

Installation method	A [mm]	B [mm]	C [mm]	Ambient temperature [°C]		Derating curve
				Max. (without derating)	Max. (with derating)	
Single installation	50	30	-	55	60	a
Side-by-side horizontal installation	50	30	30	55	60	a
Zero stack installation (except for CSS 0.55-3/3)	50	30	0	45	60	b
Zero stack installation for CSS 0.55-3/3	50	30	0	40	60	c
Side-mounting (except for CSS 0.55-3/3)	50	0	0	45	60	b
Side-mounting for CSS 0.55-3/3	50	0	0	40	60	c

Figure 4-3 Derating curve



NOTE:

The installation direction for side-mounting is different with other installation methods. Therefore, the minimum mounting clearances A ... C indicate different sides of the CONTACTRON Speed Starter, as shown in the figures below.

Figure 4-4 Single / side-by-side horizontal / zero stack installation

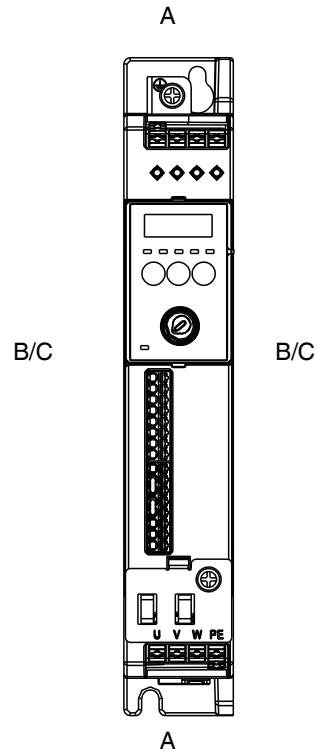
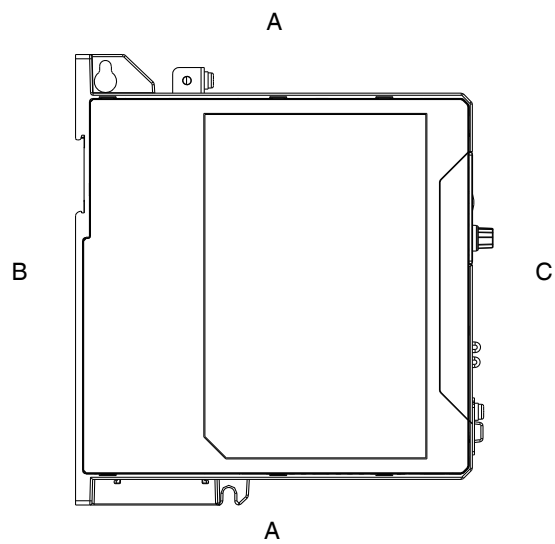
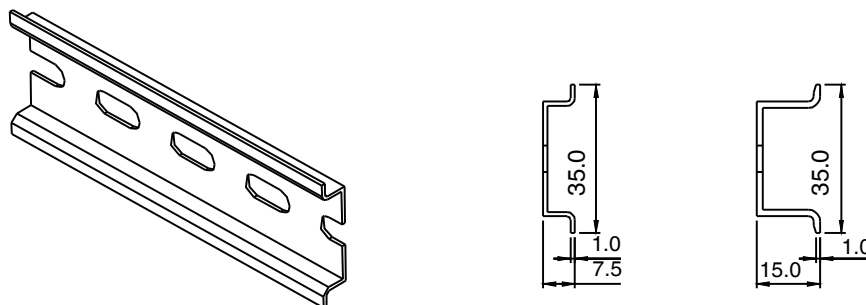

Figure 4-5 Side-mounting Installation



4.2 DIN Rail mounting

Figure 4-6 Dimensions



4.2.1 Installing the CONTACTRON Speed Starter onto the DIN rail

1. Place the CONTACTRON Speed Starter from above on the DIN rail, and push it downwards.
2. Swing the bottom of the CONTACTRON Speed Starter onto the DIN rail.

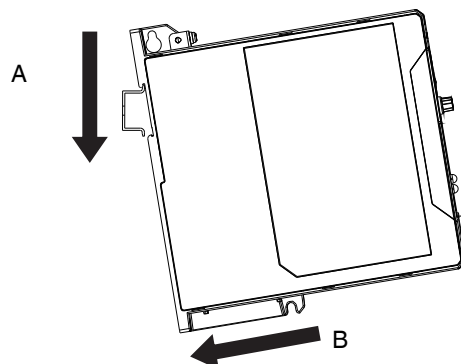

3. Push the CONTACTRON Speed Starter upwards to lock on the DIN rail.

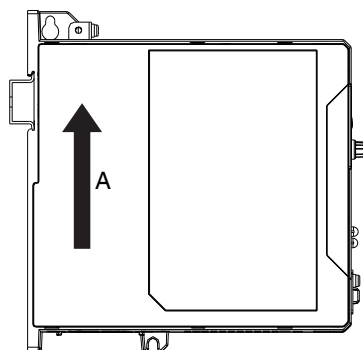

4.2.2 Removing the CONTACTRON Speed Starter from the DIN rail

1. Push the CONTACTRON Speed Starter downwards to unlock.

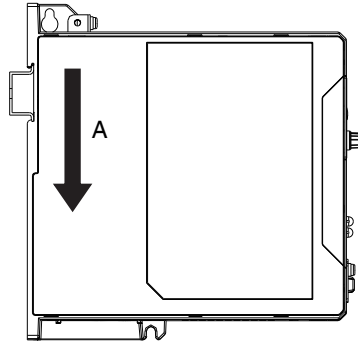

2. Lift the CONTACTRON Speed Starter from the bottom.
3. Push the CONTACTRON Speed Starter upwards to remove from the DIN rail.

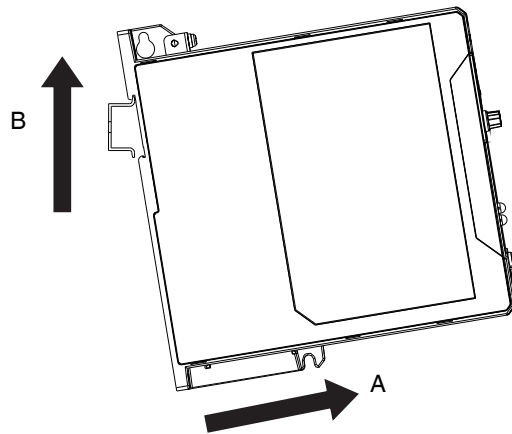

5 Wiring

5.1 Power terminals

The mains cables and motor cables must be sized as required by local standards and by the local currents that will be involved.

Figure 5-1 Power terminals

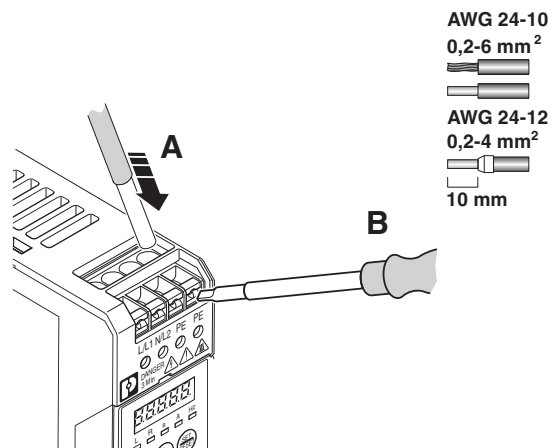

1. Insert solid or stranded conductors with ferrules directly in the clamping space (A).
2. Reliable contact can be made with stranded conductors without ferrules by opening the spring beforehand using the pushbutton (B).
3. Press the pushbutton (B) to release the conductor.

5.2 Control terminals

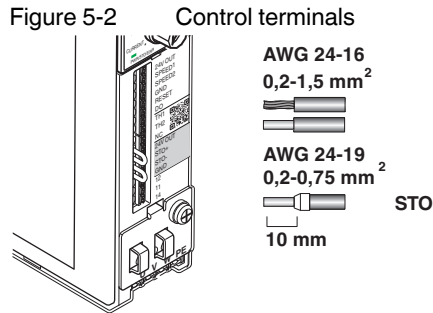

The maximum current of all 24V OUT terminals is limited to <100 mA.



The CONTACTRON Speed Starter can be controlled by the two digital inputs Speed1 and Speed2. To start the motor the digital input needs to receive a 24 V signal. This can be done in two ways:

1. Take the 24V OUT signal of the device and connect it to Speed1 and/or Speed2
2. Take a 24 V output from the PLC. In this case the GND needs to be connected to have the right potential reference.

This is the minimum wiring effort on the control side that needs to be done in order to start the motor. For further connection possibilities, check the table below.

Table 5-1 Terminal description

Terminals	Description
24V OUT	Digital control signal supply +24 V DC $\pm 10\%$ 100 mA
SPEED1	SPEED1 input
SPEED2	SPEED2 input
RESET	Reset input
GND	Common ground for digital control signals
DO	Digital output Speed1 / Speed2 active: DO output 24 V Speed1 / Speed2 not active, but ramp: DO output 24 V Speed1 / Speed2 not active and no ramp: DO output 0 V
11	Feedback relay
12	11-12: normally open
14	11-14: normally closed

Table 5-1 Terminal description [...]

Terminals	Description
TH1	To prevent the motor from damage due to overheating, use a Positive Temperature Coefficient (PTC) thermistor on the motor, and connect the thermistor output signal to the CONTACTRON Speed Starter's PTC input terminals.
TH2	
NC	Not connected
24V OUT	24 V output for STO+ signal
STO+	Factory default: STO+ jumpered to 24V OUT and STO- jumpered to GND Refer to Section "STO - Safe Torque Off" on page 103 for details.
STO-	
GND	Ground output for STO- signal

5.2.1 Wiring precautions

- Use a slotted screwdriver (2.5 mm (wide) × 0.4 mm (thick)) to press on the lever to remove the wiring.
- When wiring stranded wires, ensure that they are perfectly arranged to go through the wiring holes.
- <5 m unshielded cable
- >5 m ... <30 m unshielded twisted cable possible
- >30 m shielded cable
- 50 m maximum permissible cable length

5.2.2 PE terminal

Figure 5-3 PE terminal

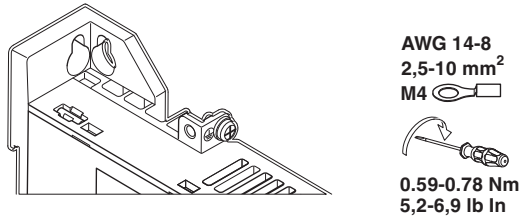

NOTE:

The specified minimum PE conductor cross-sections (IEC/EN 61800-5-1) must be maintained.

A reinforced earthing (PE) must be connected, as required by standard IEC/EN 61800-5-1. The cable cross-section must be at least 10 mm², or the earthing system must consist of two separately connected earthing cables.

The PE conductor's cross-sectional area must be the same as the phase conductor's cross-sectional area. The connection terminals marked with ⊕ must be connected to the earth-current circuit.

5.3 Wiring diagram



Only the circuit breaker or fuse is mandatory. All other components are optional.

Figure 5-4 Wiring diagram

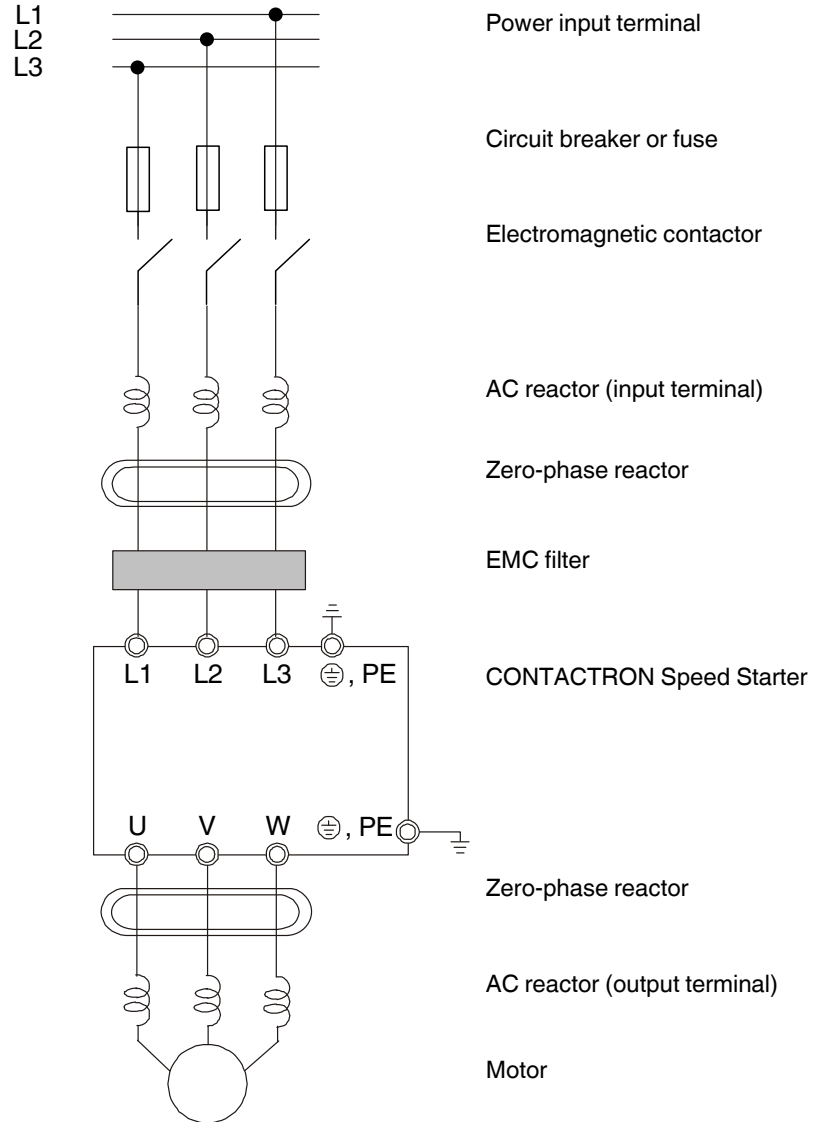

5.4 Connection possibilities



Per factory default, a STO bridge is installed between 24V OUT and STO+ and between GND and STO-.
When using the safety function, remove this STO bridge.

Figure 5-5 Input: 1-phase power

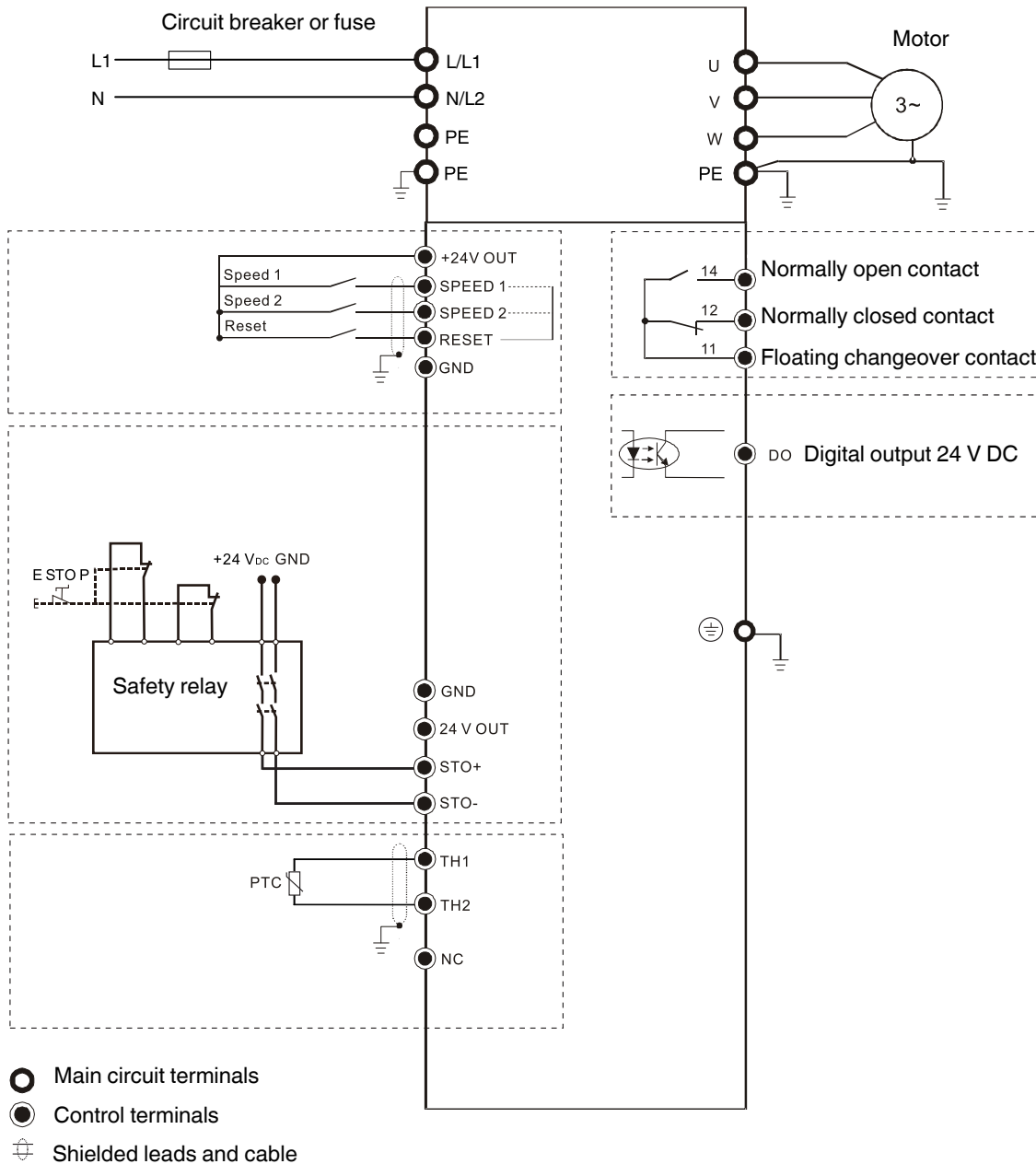
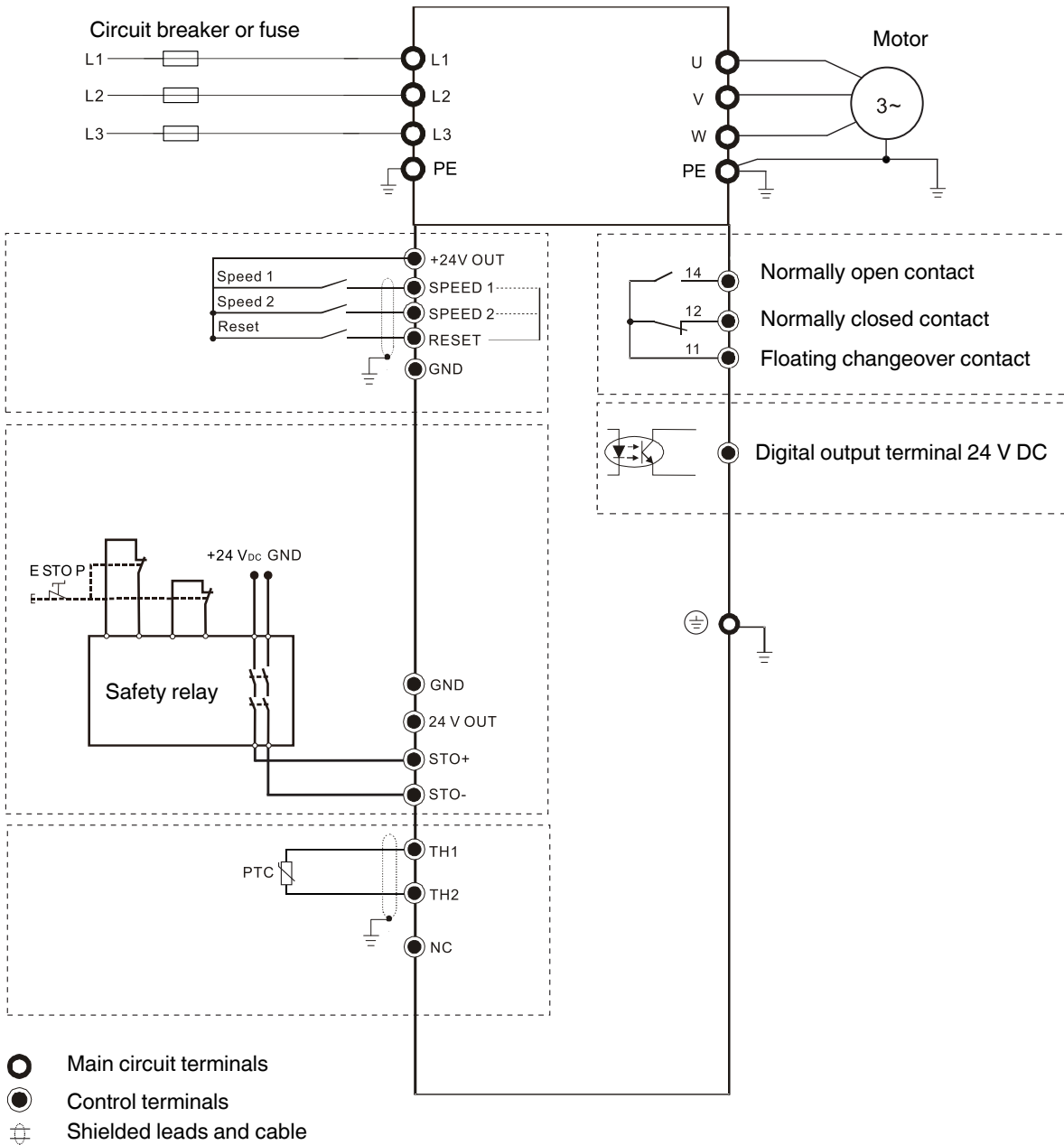

Figure 5-6 Input: 3-phase power



5.5 IT jumper



NOTE:

The jumper needs to be removed when using the CONTACTRON Speed Starter in an IT system to avoid overvoltage of components.

Otherwise, the device might be damaged.

The CONTACTRON Speed Starter contains varistors /MOVs that are connected from phase to phase to prevent the CONTACTRON Speed Starter from damage caused by mains surges or voltage spikes.

In models with a built-in EMC filter, the IT jumper connects the filter capacitors to ground to form a return path for high frequency noise in order to isolate the noise from contaminating the mains power. Removing the IT jumper strongly reduces the effect of the built-in EMC filter. Although a single CONTACTRON Speed Starter complies with the international standards for leakage current, an installation with several CONTACTRON Speed Starters with built-in EMC filters can trigger the Residual Current Device (RCD). Removing the IT jumper helps, but the EMC performance of each CONTACTRON Speed Starter is no longer guaranteed. In this case, to comply with the EMC performance, it is recommended to connect an AC reactor in front of the CONTACTRON Speed Starter.

5.5.1 Removal

1. Use a screwdriver to lift up the jumper and remove it.

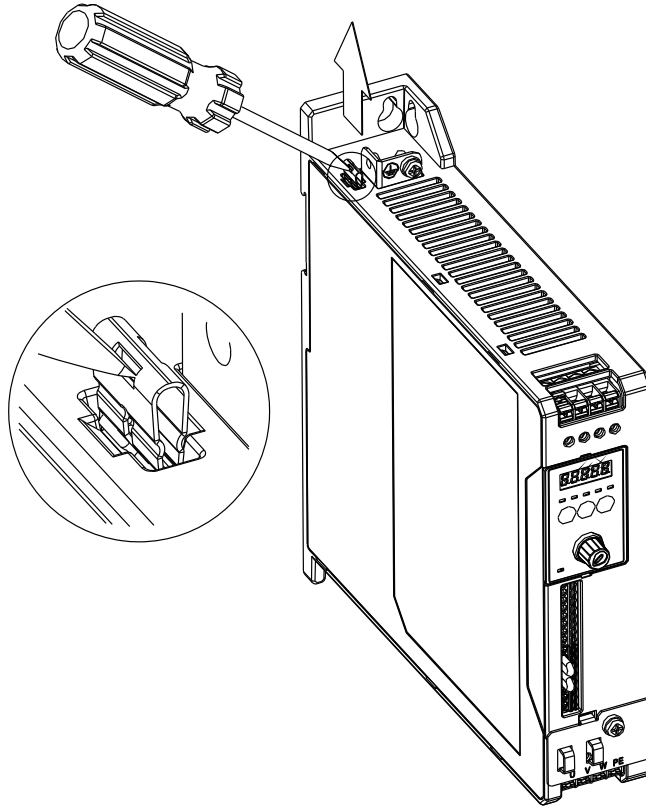

Isolating main power from ground

If the power distribution system for the CONTACTRON Speed Starter is a floating ground system (IT systems) or an asymmetric ground system (corner grounded TN systems), you must remove the IT jumper. Removing the IT jumper disconnects the internal components from ground to avoid damaging the internal circuits and to reduce the ground leakage current.

Important points regarding ground connection:

- To ensure the safety of personnel, proper operation, and to reduce electromagnetic radiation, you must properly ground the motor and CONTACTRON Speed Starter during installation.
- The diameter of the grounding cables must comply with the local safety regulations.
- You must connect the shielded cable to the CONTACTRON Speed Starter's ground to meet safety regulations.
- Only use the shielded cable as the ground for equipment when the aforementioned points are met.
- The connection of the CONTACTRON Speed Starter is just permitted in symmetric systems with a voltage from phase (phase L1, L2, L3) to neutral/earth (N/PE) of maximum 300 V.

- When installing multiple CONTACTRON Speed Starters, do not connect the grounds of the CONTACTRON Speed Starters in series but connect each CONTACTRON Speed Starter to ground. The following pictures show the correct and wrong ways to connect the grounds.

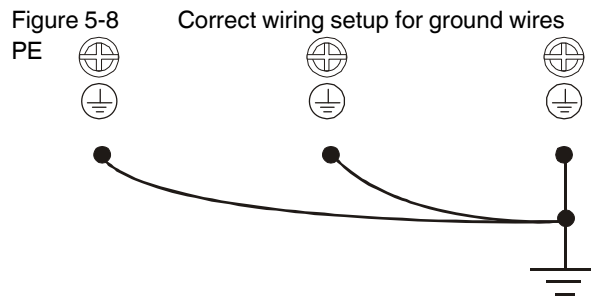
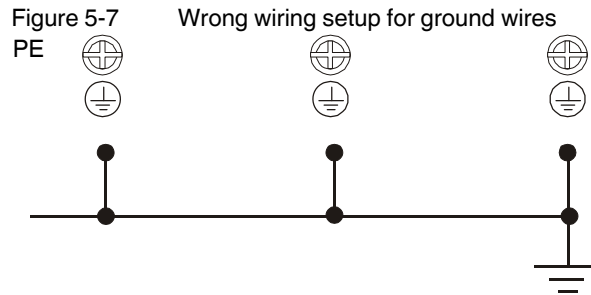

Pay particular attention to the following points:

- Do not remove the IT jumper while the power is on.
- Removing the IT jumper also cuts the capacitor conductivity of the surge absorber to ground and the built-in EMC filter capacitors. Compliance with the EMC specifications is no longer guaranteed.
- Do not remove the IT jumper if the mains power is a symmetrical grounded power system in order to maintain the efficiency for EMC circuit.
- Remove the IT jumper when conducting high voltage tests. When conducting a high voltage test to the entire facility, disconnect the mains power and the motor if the leakage current is too high.

5.5.2 Mains types

Symmetric ground system



NOTE:

If you remove the IT jumper, the CONTACTRON Speed Starter is no longer EMC compatible.

You have to make sure to observe the local EMC standards.

In a symmetrical grounding power system, you have to use the IT jumper to maintain the effect of the built-in EMC filter and surge absorber.

Figure 5-9 Symmetrical grounding power system

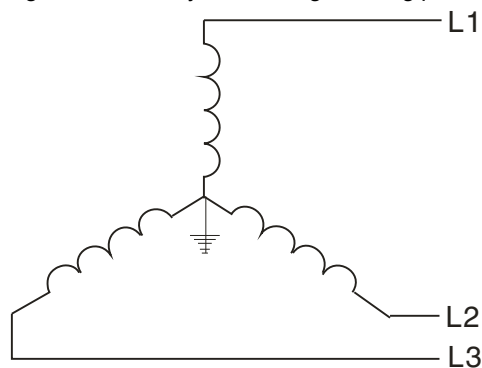

Floating ground system (IT systems)

A floating ground system is also called an IT system, an ungrounded system, or a high impedance / resistance (greater than 30 Ω) grounded system.

- Remove the IT jumper to disconnect the ground cable from the internal filter capacitor and surge absorber.
- Do not install an external RFI/EMC filter. The external EMC filter passes through a filter capacitor and connects power input to the ground. This is very dangerous and damages the CONTACTRON Speed Starter.
- In situations where EMC is required, use an EMC filter specifically for IT system if necessary. Disconnecting the ground cable from the filter prevents damage to the CONTACTRON Speed Starter but compliance with EMC is no longer guaranteed.
- If EMC is required, check for excess electromagnetic radiation affecting nearby low-voltage circuits. In some situations, the adapter and cable naturally provide enough suppression. If in doubt, install an extra electrostatic shielded cable on the power supply side between the main circuit and the control terminals to increase shielding.

Asymmetric ground system (corner grounded TN systems)



CAUTION:

Do not remove the IT jumper while power to the input terminal of the CONTACTRON Speed Starter is ON.

In the following four situations, you must remove the IT jumper. This is to prevent the system from grounding through the RFI and filter capacitors and damaging the CONTACTRON Speed Starter.



NOTE:

You must remove the IT jumper for an asymmetric ground system.

Figure 5-10 Grounding at a corner in a triangle configuration

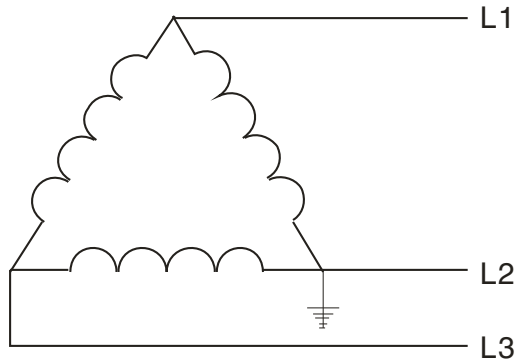

Figure 5-11 Grounding at a midpoint in a polygonal configuration

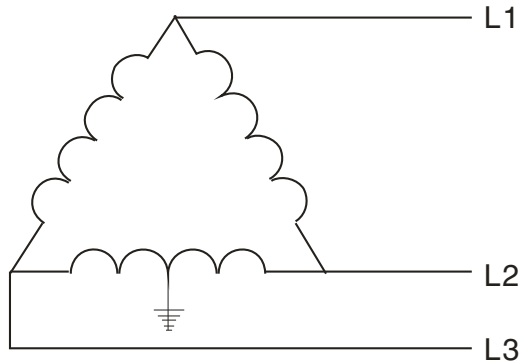

Figure 5-12 Grounding at one end in a single-phase configuration

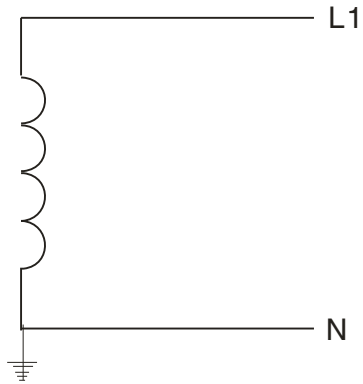
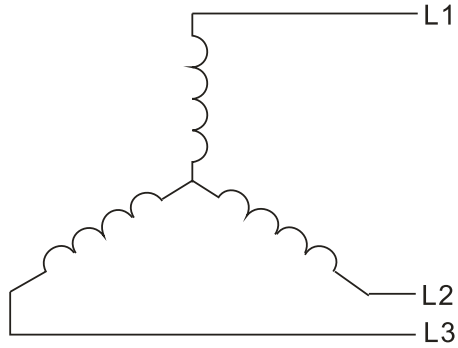

Figure 5-13 No stable neutral grounding in a three-phase autotransformer configuration



5.6 Motor cable length

5.6.1 Consequence of leakage current

If the cable length is too long, the stray capacitance between cables increases and may cause leakage current. In this case, it activates the over-current protection, increases leakage current, or may affect the current display. The worst case is that it may damage the CONTACTRON Speed Starter. If more than one motor is connected to one CONTACTRON Speed Starter, the total wiring length should be the sum of the wiring length from the CONTACTRON Speed Starter to each motor.

5.6.2 Consequence of the surge voltage

When a motor is controlled by a CONTACTRON Speed Starter, the motor terminals experience surge voltages ($\Delta v / \Delta t$) due to power transistor conversion of CONTACTRON Speed Starter. When the motor cable is very long (especially for the 480 V models), surge voltages ($\Delta v / \Delta t$) may damage the motor insulation and bearing. To prevent this, follow these rules:

- Use a motor with enhanced insulation.
- Reduce the cable length between the CONTACTRON Speed Starter and motor to suggested values.
- Connect an output reactor (optional) to the output terminals of the CONTACTRON Speed Starter.

Refer to the following tables for the suggested motor cable length.



You have to make sure to observe the local EMC standards.

Table 5-2 Maximum motor cable length at 4 kHz carrier frequency (1-phase)

Device type		CSS X.XX-1/3		CSS X.XX-1/3-EMC
Output AC reactor		x	-	-
Input external EMC filter		-	x	-
Output zero-phase reactor		-	x	-
Shielded cable	Without EMC category	75 m	50 m	50 m
	Category C1	N/A	30 m (CE only)	N/A
	Category C2	N/A	50 m	20 m
	Category C3	N/A	50 m	20 m
Unshielded cable		115 m	75 m	75 m

Table 5-3 Maximum motor cable length at 4 kHz carrier frequency (3-phase)

Device type		CSS X.XX-3/3		CSS X.XX-3/3-EMC
Output AC reactor		x	-	-
Input external EMC filter		-	x	-
Output zero-phase reactor		-	x	-
Shielded cable	without EMC category	75 m	50 m	50 m
	Category C1	N/A	30 m (CE only)	N/A
	Category C2	N/A	50 m	N/A
	Category C3	N/A	50 m	30 m
Unshielded cable		115 m	75 m	75 m

6 Main circuit diagram

Figure 6-1 Input: 1-phase power

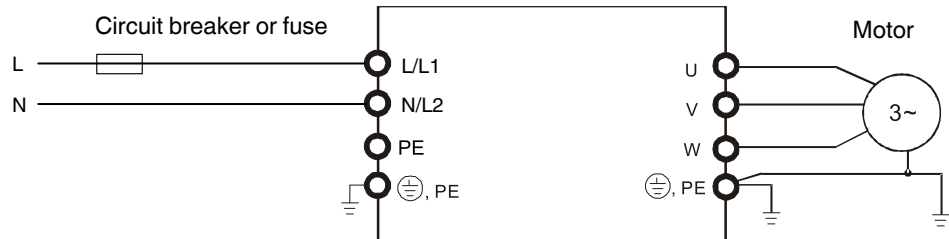
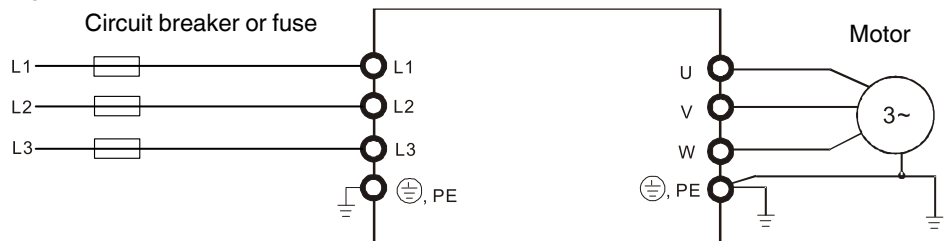

Figure 6-2 Input: 3-phase power



Terminals	Description
L/L1, N/L2	Mains input terminals (1-phase)
L1, L2, L3	Mains input terminals (3-phase)
U, V, W	CONTACTRON Speed Starter output terminals for connecting three-phase asynchronous motors (ASM)
⊕, PE	Ground connection, comply with local regulations.

7 Standard fuses and circuit breakers

7.1 Standard fuses (for IEC)

The standard fuses (for IEC) have been tested according to IEC/EN 61800-5-1.

Table 7-1 Protection with standard fuses (IEC)

CONTACTRON Speed Starter			Fuse type (IEC)		
Mains	Models	Power [kW]	SCCR [kA]	Fuse type	Max. rated current [A]
1-phase	CSS 0.25-1/3	0.25	30	gG	16
	CSS 0.37-1/3	0.37	30	gG	16
	CSS 0.55-1/3	0.55	30	gG	16
	CSS 0.75-1/3	0.75	30	gG	16
	CSS 1.5-1/3	1.5	30	gG	32
	CSS 0.25-1/3-EMC	0.25	30	gG	16
	CSS 0.37-1/3-EMC	0.37	30	gG	16
	CSS 0.55-1/3-EMC	0.55	30	gG	16
	CSS 0.75-1/3-EMC	0.75	30	gG	16
	CSS 1.5-1/3-EMC	1.5	30	gG	32
3-phase	CSS 0.25-3/3	0.25	30	gG	16
	CSS 0.37-3/3	0.37	30	gG	16
	CSS 0.55-3/3	0.55	30	gG	16
	CSS 0.75-3/3	0.75	30	gG	16
	CSS 1.5-3/3	1.5	30	gG	16
	CSS 0.25-3/3-EMC	0.25	30	gG	16
	CSS 0.37-3/3-EMC	0.37	30	gG	16
	CSS 0.55-3/3-EMC	0.55	30	gG	16
	CSS 0.75-3/3-EMC	0.75	30	gG	16
	CSS 1.5-3/3-EMC	1.5	30	gG	16

7.2 Standard fuses and circuit breakers (for UL and cUL)

You can choose either fuses or circuit breakers for Branch Circuit Protection (BCP) according to your needs. Refer to the following specifications for details.

The standard fuses and circuit breakers (for UL and cUL) have been tested according to UL 61800-5-1.



NOTE:

When installing a single motor and the fuse value is >400 % of the motor current (full load amps), the fuse value has to be calculated.

If the calculated value is between two standard ratings, the nearest standard rating less than the calculated has to be used.

When installing a single motor the maximum current of the fuse must be less than 400 % of the full-load motor output current.

7.2.1 Branch circuit protection with standard fuses

The standard fuses with Short Circuit Current Ratings (SCCR) in [Table 7-2](#) are suitable for motor group installation.

Table 7-2 Standard fuses with SCCR (UL and cUL)

CONTACTRON Speed Starter			Fuse type (UL 248)			
Mains	Models	Power [kW]	SCCR [kA]	Fuse type	Max. rated current [A]	Min. cabinet dimensions [mm]
1-phase	CSS 0.25-1/3	0.25	65	T, J, CC	15	500 x 400 x 250
	CSS 0.37-1/3	0.37	65	T, J, CC	15	500 x 400 x 250
	CSS 0.55-1/3	0.55	65	T, J, CC	15	500 x 400 x 250
	CSS 0.75-1/3	0.75	65	T, J, CC	15	500 x 400 x 250
	CSS 1.5-1/3	1.5	65	T, J, CC	30	500 x 400 x 250
	CSS 0.25-1/3-EMC	0.25	65	T, J, CC	15	500 x 400 x 250
	CSS 0.37-1/3-EMC	0.37	65	T, J, CC	15	500 x 400 x 250
	CSS 0.55-1/3-EMC	0.55	65	T, J, CC	15	500 x 400 x 250
	CSS 0.75-1/3-EMC	0.75	65	T, J, CC	15	500 x 400 x 250
	CSS 1.5-1/3-EMC	1.5	65	T, J, CC	30	500 x 400 x 250

Table 7-2 Standard fuses with SCCR (UL and cUL)

CONTACTRON Speed Starter			Fuse type (UL 248)			
Mains	Models	Power [kW]	SCCR [kA]	Fuse type	Max. rated current [A]	Min. cabinet dimensions [mm]
3-phase	CSS 0.25-3/3	0.25	65	T, J, CC	15	500 x 400 x 250
	CSS 0.37-3/3	0.37	65	T, J, CC	15	500 x 400 x 250
	CSS 0.55-3/3	0.55	65	T, J, CC	15	500 x 400 x 250
	CSS 0.75-3/3	0.75	65	T, J, CC	15	500 x 400 x 250
	CSS 1.5-3/3	1.5	65	T, J, CC	15	500 x 400 x 250
	CSS 0.25-3/3-EMC	0.25	65	T, J, CC	15	500 x 400 x 250
	CSS 0.37-3/3-EMC	0.37	65	T, J, CC	15	500 x 400 x 250
	CSS 0.55-3/3-EMC	0.55	65	T, J, CC	15	500 x 400 x 250
	CSS 0.75-3/3-EMC	0.75	65	T, J, CC	15	500 x 400 x 250
	CSS 1.5-3/3-EMC	1.5	65	T, J, CC	15	500 x 400 x 250

7.2.2 Branch circuit protection with circuit breakers

The circuit breakers with SCCR in [Table 7-3](#) are suitable for motor group installation.

Table 7-3 Circuit breakers with SCCR (UL and cUL)

CONTACTRON Speed Starter			Circuit breaker (UL 489)		
Mains	Models	Power [kW]	SCCR [kA]	Max. rated current [A]	Min. cabinet dimensions [mm]
1-phase	CSS 0.25-1/3	0.25	65	32	500 x 400 x 250
	CSS 0.37-1/3	0.37	65	32	500 x 400 x 250
	CSS 0.55-1/3	0.55	65	32	500 x 400 x 250
	CSS 0.75-1/3	0.75	65	32	500 x 400 x 250
	CSS 1.5-1/3	1.5	65	32	500 x 400 x 250
	CSS 0.25-1/3-EMC	0.25	65	32	500 x 400 x 250
	CSS 0.37-1/3-EMC	0.37	65	32	500 x 400 x 250
	CSS 0.55-1/3-EMC	0.55	65	32	500 x 400 x 250
	CSS 0.75-1/3-EMC	0.75	65	32	500 x 400 x 250
	CSS 1.5-1/3-EMC	1.5	65	32	500 x 400 x 250
3-phase	CSS 0.25-3/3	0.25	65	10	500 x 400 x 250
	CSS 0.37-3/3	0.37	65	10	500 x 400 x 250
	CSS 0.55-3/3	0.55	65	10	500 x 400 x 250
	CSS 0.75-3/3	0.75	65	10	500 x 400 x 250
	CSS 1.5-3/3	1.5	65	10	500 x 400 x 250
	CSS 0.25-3/3-EMC	0.25	65	10	500 x 400 x 250
	CSS 0.37-3/3-EMC	0.37	65	10	500 x 400 x 250
	CSS 0.55-3/3-EMC	0.55	65	10	500 x 400 x 250
	CSS 0.75-3/3-EMC	0.75	65	10	500 x 400 x 250
	CSS 1.5-3/3-EMC	1.5	65	10	500 x 400 x 250

8 Accessories and spare parts

8.1 EMC shielding plate

EMC shielding plate for use with shielded cable and steel cable tie WT-STEEL S 4,6 × 150 (art.-no.: 3240807).

Table 8-1 Accessories

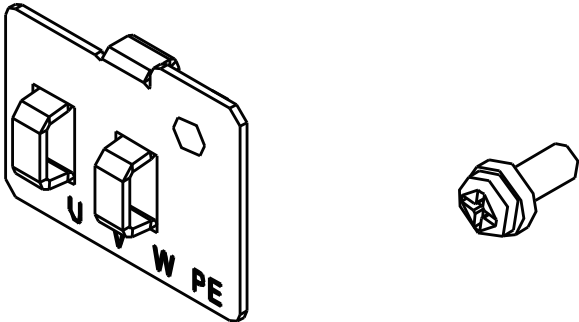
Frame	Model of EMC shielding plate	Reference figure
A	<p data-bbox="300 793 357 856">i</p> <p data-bbox="387 800 783 1020">If you use shielded control wires, strip the end of the wire. Attach the shielded cable end with the cable tie 3240807 by putting the cable tie through the loops. Connect the unshielded wires to the control terminal block.</p>	

CONTACTRON Speed Starter

Table 8-1 Accessories

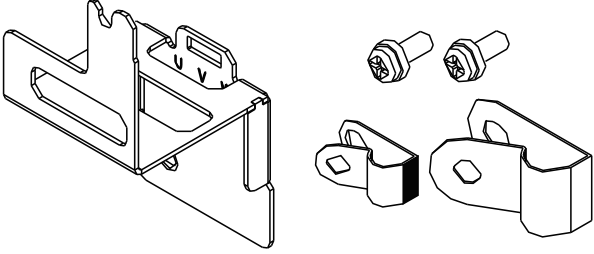
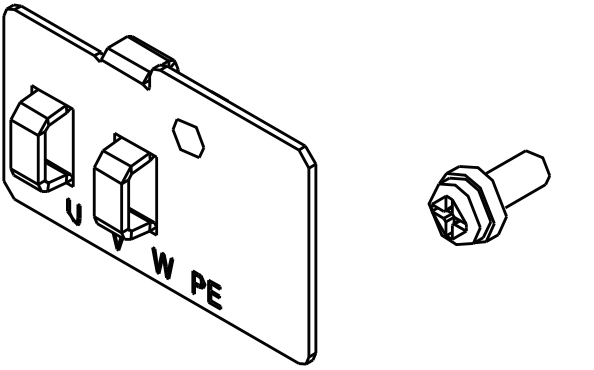
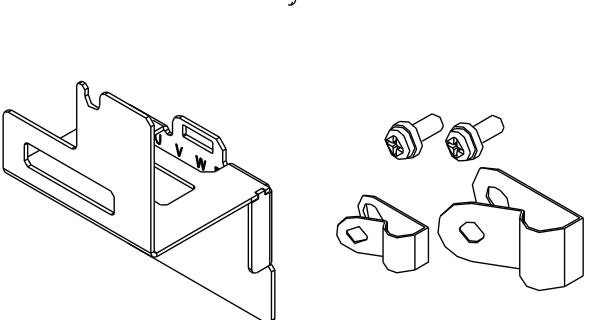
Frame	Model of EMC shielding plate	Reference figure
A	EM-CSS-MOTORSHIELD-35	
B	<p>i If you use shielded control wires, strip the end of the wire.</p> <p>Attach the shielded cable end with the cable tie 3240807 by putting the cable tie through the loops.</p> <p>Connect the unshielded wires to the control terminal block.</p>	
B	EM-CSS-MOTORSHIELD-45	

8.1.1 Installation

8.1.1.1 Model: EM-CSS-CONTROLSHIELD-35/45

1. As shown in the figure below, put the EMC shielding plate on the CONTACTRON Speed Starter.

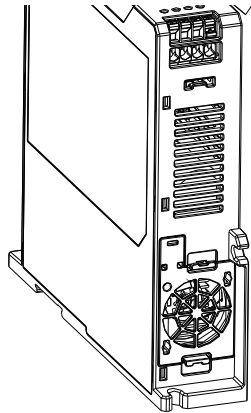

2. Use the screw in the accessories to fix the EMC shielding plate on the CONTACTRON Speed Starter.

Screw torque: 0.59 Nm ... 0.78 Nm [5.2 lb-in ... 6.9 lb-in]

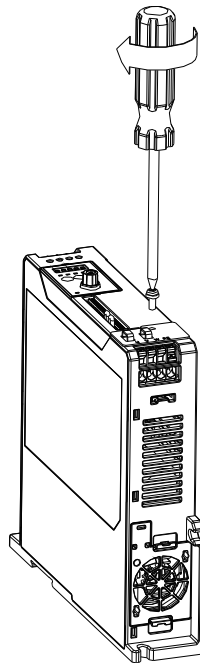

8.1.1.2 Model: EM-CSS-MOTORSHIELD-35/45

1. As shown in the figure below, loosen the screw from the EMC shielding plate installed on the CONTACTRON Speed Starter.

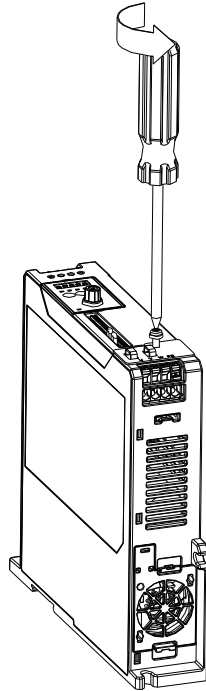

- Put the EMC shielding plate for the motor output on the EMC shielding plate for the control terminals, then fasten back the screw.

Screw torque: 0.59 Nm ... 0.78 Nm [5.2 lb-in ... 6.9 lb-in]

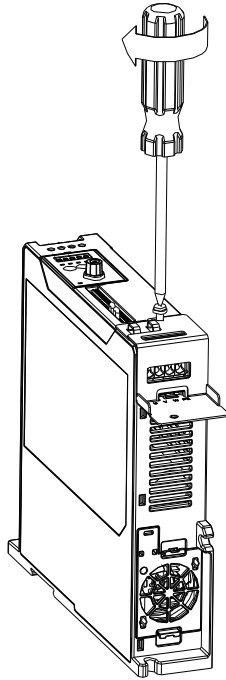

- As shown in the figure below, fix the R-type wire clamp on the EMC shielding plate.

Screw torque: 0.59 Nm ... 0.78 Nm [5.2 lb-in ... 6.9 lb-in]

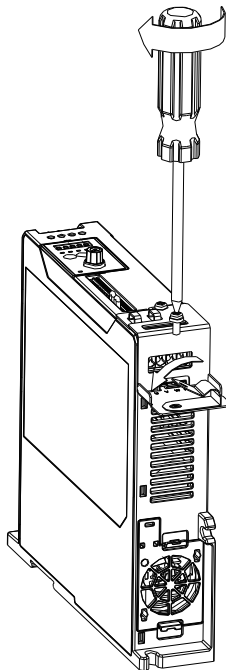

8.2 Fan kit



Use EM-CSS-FAN-35 (art.-no.: 1276911) for the following models:

- CSS 0.25-1/3 (art.-no.: 1201132)
- CSS 0.37-1/3 (art.-no.: 1201135)
- CSS 0.25-1/3-EMC (art.-no.: 1201520)
- CSS 0.37-1/3-EMC (art.-no.: 1201600)
- CSS 0.25-3/3 (art.-no.: 1201679)
- CSS 0.37-3/3 (art.-no.: 1201683)
- CSS 0.55-3/3 (art.-no.: 1201694)
- CSS 0.25-3/3-EMC (art.-no.: 1201713)
- CSS 0.37-3/3-EMC (art.-no.: 1201825)
- CSS 0.55-3/3-EMC (art.-no.: 1201828)
- CSS 0.75-3/3-EMC (art.-no.: 1201829)



Use EM-CSS-FAN-45 (art.-no.: 1276912) for the following models:

- CSS 0.55-1/3 (art.-no.: 1201494)
- CSS 0.75-1/3 (art.-no.: 1201509)
- CSS 1.5-1/3 (art.-no.: 1201511)
- CSS 0.55-1/3-EMC (art.-no.: 1201602)
- CSS 0.75-1/3-EMC (art.-no.: 1201613)
- CSS 1.5-1/3-EMC (art.-no.: 1201642)
- CSS 0.75-3/3 (art.-no.: 1201695)
- CSS 1.5-3/3 (art.-no.: 1201650)
- CSS 1.5-3/3-EMC (art.-no.: 1201696)

Figure 8-1 Fan kit EM-CSS-FAN-35 (art.-no. 1276911)

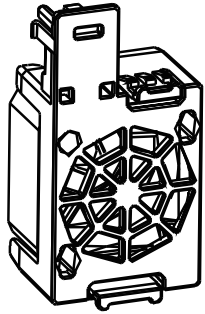
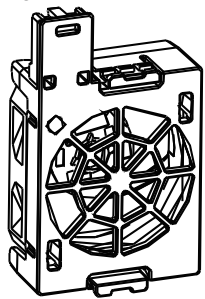

Figure 8-2 Fan kit EM-CSS-FAN-45 (art.-no. 1276912)



8.2.1 Fan removal

As shown in the figure below, press the tabs on both side of the fan to remove the fan.

Figure 8-3 Fan removal

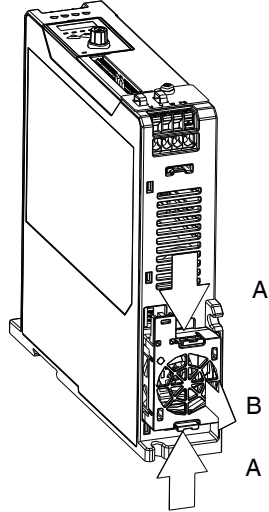

8.2.2 Fan installation

As shown in the figure below, push the fan to install.

Figure 8-4 Fan installation

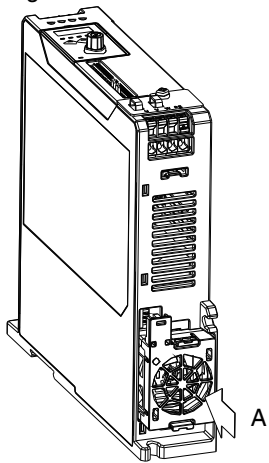

9 Control panel

9.1 Panel

Figure 9-1 Control panel

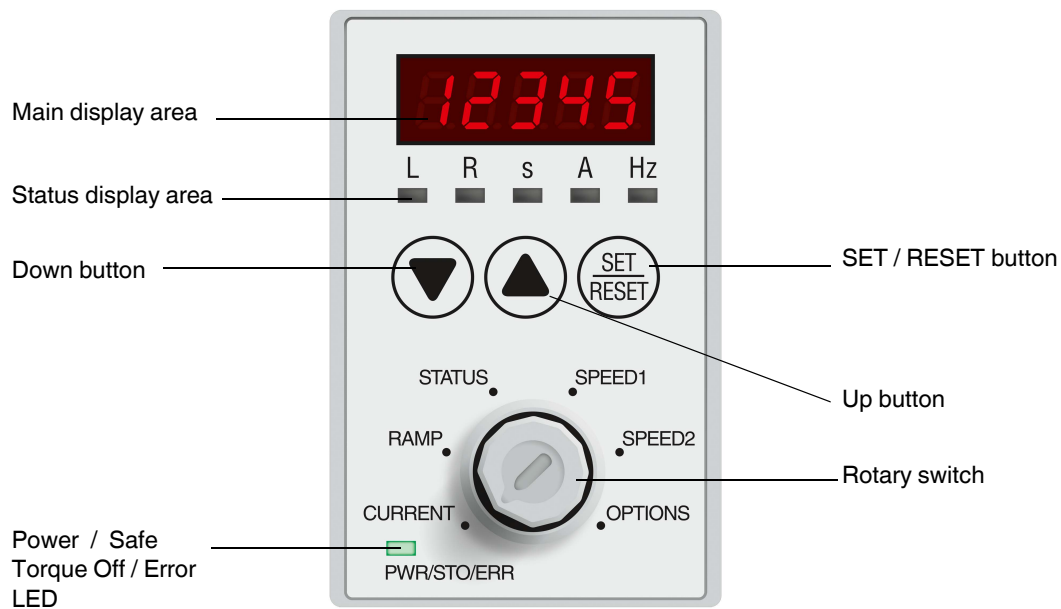
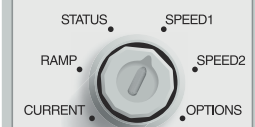
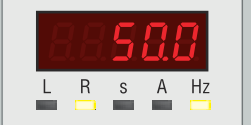
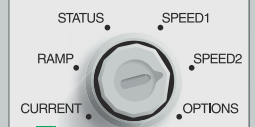
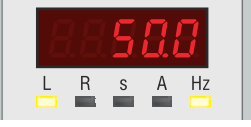
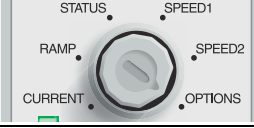



Table 9-1 Descriptions of functions

Rotary switch	Displayed items	Description
		Display shows the parameterized motor rated current [A] 10.1 on page 73
		Display shows the parameterized ramp time [s] 10.2 on page 74
		Display shows certain physical output values 10.3 on page 75

CONTACTRON Speed Starter

Table 9-1 Descriptions of functions

Rotary switch	Displayed items	Description
		<p>Display shows the stored frequency and the stored direction of rotation</p> <p>10.4 on page 76</p>
		<p>Display shows the stored frequency and the rotation</p> <p>10.4 on page 76</p>
		<p>Display shows different options</p> <p>10.5 on page 77</p>

9.2 Control panel operation process

- i
If you turn the rotary switch while the value displayed on the control panel still flashes, the value is not stored into the device.
- i
If you change a value and do not press any button for more than 30 s, the stored value appears again and does not flash any more.
- i
Press [UP] or [DOWN] for less than 1 s first, the value does not change but starts to flash. If pressing these buttons again or longer than 1 s, then the value gets higher or lower depending on the button you press.
- i
Press the [SET/RESET] for 0.5 s ... 3 s to acknowledge an error.
- i
When pressing [UP] or [DOWN], the value changes for 0.1 per step.
- i
If pressing the button for longer than 0.5 s, the value changes for 0.5 per step. If pressing the button for longer than 2 s, the value changes for 1.0 per step.

9.2.1 Rotary switch in "CURRENT" position

LED "A" is ON, and display shows the parameterized motor rated current [A] [10.1 on page 73](#).

Factory default is the highest value that can be set according to the power class.

	For a lower current, press [DOWN].	For a higher current, press [UP].
	The value in the display changes (0.1-steps) and starts to flash.	
	Press [SET/RESET] to store the value.	
	The displayed value stops flashing and is stored.	

You can set the parameter for CURRENT level during operation.

9.2.2 Rotary switch in "RAMP" position

LED "s" is ON, display shows the parameterized ramp time [s] [10.2 on page 74](#).

Factory default is 1.0 s.

	For a shorter ramp, press [DOWN].	For a longer ramp, press [UP].
	The value in the display changes (0.1-steps) and starts to flash.	
	Press [SET/RESET] to store the value.	
	The displayed value stops flashing and is stored.	

You can set the parameter for RAMP time value during operation.

9.2.3 Rotary switch in "STATUS" position

"STATUS" shows the active status of the device. To see the status, you need to turn the rotary switch to "STATUS". If there is no signal (SPEED1, SPEED2), the display shows 0.0 Hz. If there is a signal, the display shows the rising frequency value. The LED "L" or "R" turns ON depending on the given signal and the corresponding direction setting. The value displayed on the control panel is fixed when the given signal reaches the stored value. The display shows the decreasing value when there is no more input signal. When the ramp time is over, the display shows 0.0 Hz again. Any received signal is shown as SP1, SP2 on the control panel for 1 s in every 4 s.

This parameter shows different status values as listed below, change it with [UP] or [DOWN].

Figure 9-2 Status display

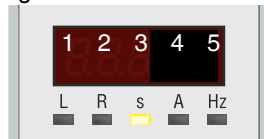

Number 1 ... 5 indicate digits 1 ... 5 mentioned in the table below.

Table 9-2 Status description

Status	LED	Displayed value
Output frequency	"L" or "R" LEDs ON in case of a signal, "Hz" LED ON	-
Output current	"L" or "R" LEDs ON in case of a signal, "A" LED ON	-
Output voltage	"L" or "R" LEDs ON in case of a signal	"v" shows on digit 5
Output power factor (cos phi)	"L" or "R" LEDs ON in case of a signal	"q" shows on digit 1
Active power [kW]	"L" or "R" LEDs ON in case of a signal	"P" shows on digit 1
IGBT temperature	"L" or "R" LEDs ON in case of a signal	"°C" shows on digit 1 and 2

Refer to [Section "Rotary switch in "STATUS" position" on page 75](#) for details.

9.2.4 Rotary switch in "SPEED1" / "SPEED2" position when STOP

The display shows the stored frequency and the LED "Hz" is on. Depending on the stored direction, the LED "R" or "L" is ON.

Factory default is 50.0 Hz.

The maximum value depends on the parameter "3. oF - highest output frequency" and the minimum value is 0.0 Hz.

	For a lower speed, press [DOWN].	For a higher speed, press [UP].
	The value in the display changes (0.1-steps) and starts to flash.	
	Press [SET / RESET] to store the value.	
	The displayed value stops flashing and is stored.	
	LED "R" (depending on the stored direction) starts to flash.	
	Press [DOWN] or [UP] to change the running direction.	
	"R" changes to "L" (backwards if press the buttons again) and keeps flashing.	
	Press [SET / RESET] to store the setting for running direction.	

9.2.5 Rotary switch in "SPEED1" / "SPEED2" when RUNNING

The display shows the stored frequency and the LED "Hz" is on. Depending on the stored direction, the LED "R" or "L" is ON.

Factory default is 50.0 Hz.

"SP1" appears for 1 s in every 4 s.

 <p>The image shows a control panel with a red digital display showing '50.0'. Above the display are five LEDs labeled L, R, s, A, and Hz. Below the display are two buttons with downward and upward arrows, and a circular button labeled 'SET / RESET'. A rotary switch is positioned below these buttons, with labels 'STATUS', 'SPEED1', 'RAMP', 'SPEED2', 'CURRENT', and 'OPTIONS' around it. At the bottom left, there is a green LED labeled 'PWR/STO/ERR'.</p>	For a lower speed, press [DOWN].	For a higher speed, press [UP].
	The value in the display changes (0.1-steps) and starts to flash.	
	Press [SET / RESET] to store the value.	
	The displayed value stops flashing and is stored.	

The direction cannot be changed if there is a run signal.

9.2.6 Rotary switch in "SPEED1" or "SPEED2" position for direction setting at STOP

Follow these steps for direction setting.

	Press [SET / RESET] for 3 s	Press [UP] or [DOWN]
		The displayed value (frequency) starts flashing
		Press [SET / RESET] to confirm
	The displayed value changes to "L" or "R", then starts flashing.	
	Press [UP] or [DOWN] to change the running direction	
The direction LED changes (from "L" to "R" or from "R" to "L") once you press [UP] or [DOWN] and keeps flashing after the setting.		
Press [SET / RESET] to store the value. The displayed value stops flashing and is stored.		

9.2.7 Rotary switch in "OPTIONS" position

Turn the rotary switch to "OPTIONS" to set options and parameters.

The following are descriptions for the options.

Refer to [Section "Rotary switch in "OPTIONS" position" on page 77](#) for details.

CONTACTRON Speed Starter

Table 9-3 Options and their description

	Options	Description
 <p>The image shows the CONTACTRON Speed Starter control panel. It features a red LED digital display showing '9 PFC'. Below the display are four indicator LEDs labeled L, R, s, and A, followed by 'Hz'. There are two triangular buttons (up and down) and a circular 'SET / RESET' button. A rotary switch is labeled with 'STATUS', 'SPEED1', 'RAMP', 'SPEED2', 'CURRENT', 'OPTIONS', and 'PWR/STO/ERR'. A small green LED indicator is also present.</p>	Motor rated frequency (0 Hz ... 500 Hz)	"1. rF - motor rated frequency" shown on the display, from motor nameplate
	Motor rated voltage 1-phase device: 110 V ... 240 V 3-phase device: 220 V ... 480 V	"2. rv - motor rated voltage" shown on the display , from motor nameplate
	Highest output frequency (0 Hz ... 500 Hz)	"3. oF - highest output frequency" shown on the display
	Pulse frequency (4 kHz, 8 kHz, 16 kHz, AUTO)	"4. PF - pulse frequency" shown on the display Set "AUTO" for the derating carrier frequency, setting 4, 8, 16 are fixed value without derating.
	V/F waveform (linear / square)	"5. vF - vF wave form" shown on the display
	Start boost (0 % ... 10 %)	"6. bo - start boost" shown on the display
	Voltage lift (0 % ... 10 %)	"7. vL - voltage lift" shown on the display
	Slip compensation (0 % ... 10 %)	"8. Sc- slip compensation" shown on the display
	PTC (enabled / disabled)	"9. PTC - PTC active" shown on the display
	Parameter lock (yes / no)	"10. PL - parameter lock" shown on the display When setting Parameter lock to "yes", only the stored value shows on the display and LEDs while turning the rotary switch. You cannot change the stored value until the Parameter lock is set to "no".
	Parameter reset	"11.res - parameter reset" shown on the display Default is "no". When the "rESEt" shows on the display, change to "yes" and then [SET / RESET] to reset. After resetting, the "11.res - parameter reset" returns to "no".
	CONTACTRON Speed Starter type	"12. ID - identity code" shown on the display
	Firmware version	"13.ver - firmware version" shown on the display
	Relay output	"14. FC - feedback contact" shown on the display

Follow these steps for the OPTIONS setting:

1. Turn rotary switch to "OPTIONS".
2. Use [UP] or [DOWN] to choose the options / parameters that are going to change.
3. Use [SET / RESET] for setting.
The stored value of the chosen parameter is shown on the display.
4. Press [UP] or [DOWN] to change the setting value, and the changed value starts to flash.
5. Press [SET / RESET] key to store the value: the stored value shows on the display for 2 s (without flashing), then the display returns to the parameter name.
6. Use [UP] or [DOWN] to select other parameter to be changed.
7. If you choose a parameter without setting, the value of this parameter shows on the display for 10 s, then returns to the parameter name.

9.3 Status summary

Table 9-4 Status overview

STOP status		RUNNING status			
No FREQUENCY/RUN command		FREQUENCY/RUN command from SPEED1		FREQUENCY/RUN command from SPEED2	
Rotary switch	Display	Rotary switch	Display	Rotary switch	Display
CURRENT	Stored value of CURRENT "A" LED ON	CURRENT	4 s display for the stored value of CURRENT, 1 s display for "SP1" "A" LED ON	CURRENT	4 s display for the stored value of CURRENT, 1 s display for "SP2" "A" LED ON
RAMP	Stored value of RAMP "S" LED ON	RAMP	4 s display for the stored value of RAMP, 1 s display for "SP1" "S" LED ON	RAMP	4 s display for the stored value of RAMP, 1 s display for "SP2" "S" LED ON
STATUS	0.0 Hz "Hz" LED ON	STATUS	4 s display for the output frequency 1 s display for "SP1" "R" LED ON	STATUS	4 s display for the output frequency 1 s display for "SP2" "L" LED ON
SPEED1	SP1 frequency command value "L" or "R" LED ON and "Hz" LED ON	SPEED1	4 s display for SP1 frequency command 1 s display for "SP1" "R" LED ON and "Hz" LED ON	SPEED1	4 s display for SP1 frequency command 1 s display for "SP2" "R" LED ON and "Hz" LED ON
SPEED2	SP2 frequency command value "L" or "R" LED ON and "Hz" LED ON	SPEED2	4 s display for SP2 frequency command 1 s display for "SP1" "L" LED ON and "Hz" LED ON	SPEED2	4 s display for SP2 frequency command 1 s display for "SP2" "L" LED ON and "Hz" LED ON
OPTIONS	Scrolling display, 1._rF_-_motor_rated_frequency	OPTIONS	Scrolling display, 1._rF_-_motor_rated_frequency	OPTIONS	Scrolling display, 1._rF_-_motor_rated_frequency

10 Description of parameter settings

10.1 Rotary switch in "CURRENT" position

The CONTACTRON Speed Starter has an integrated full motor protection. The device has an integrated tripping class curve (see [Figure 10-1](#)). If the load of the motor is higher than the nominal current, the device will trip according to this curve. Additionally, the device has an integrated thermal memory. This means that in case of a high load the curve will be loaded up and leads to a faster tripping time. The tripping of the device is dependent on the frequency. A low frequency leads to a quicker load of the thermal memory and a high frequency will react slower.

Can be set during operation	Leading alphabet	Parameter name	Setting range	Factory default
✓	-	Motor rated current	0.1 ... rated current of the CONTACTRON Speed Starter	Rated current of the CONTACTRON Speed Starter

Figure 10-1 Tripping curve

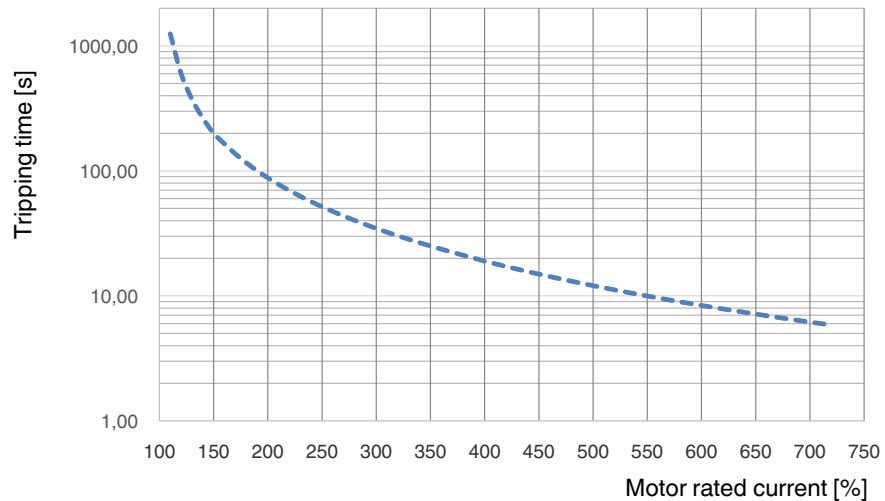

10.2 Rotary switch in "RAMP" position

In this position you can set the acceleration and deceleration time. The maximum value is up to 100 s. The adjustment time means the required time for the parameter to accelerate from 0 Hz to the reference point 50 Hz. The actual acceleration time is proportional to the change in speed (Δn).

Can be set during operation	Leading alphabet	Parameter name	Setting range	Factory default
✓	-	Ramp time	0.1 s ... 100.0 s	1.0

$$\Delta t = \frac{T_{\text{Ramp}}}{50 \text{ Hz}} \times \Delta f$$

Δt = acceleration time for Δf

Δf = frequency change

Figure 10-2 Acceleration and deceleration time
f [Hz]

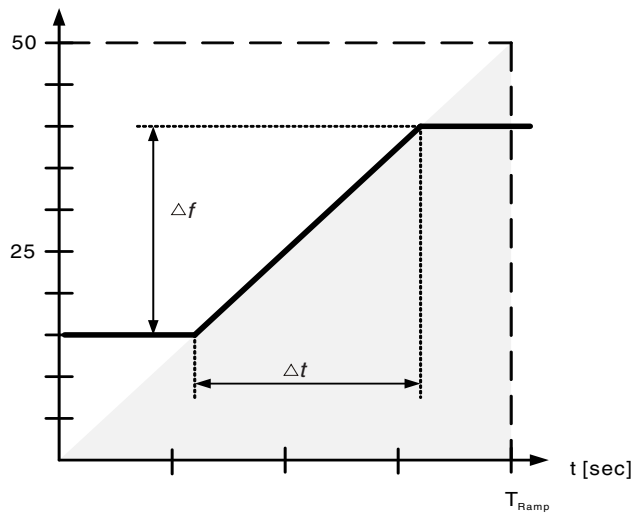

10.3 Rotary switch in "STATUS" position

In this position different status values are shown such as output frequency (Hz), output current (A), output voltage (V), output power factor (cos phi), PTC, output power (kW), and IGBT temperature (°C). Change the display values with [UP] or [DOWN].

When the output frequency status is in display, "Hz" is shown.

When the output current status is in display, "A" is shown.

When the output voltage status is in display, "v" is shown in position 5.

When the output power factor status is in display, "q" is shown in position 1.

When power status is in display, "P" is shown in position 1.

When IGBT temperature is in display, "°C" is shown in position 1 and 2.

LED numbers 1 ... 5 indicate the displayed digit from left to right on the control panel, as shown in the figure below.

Figure 10-3 Displayed digits



Can be set during operation	Leading alphabet	Parameter name	Setting range	Factory default
-	-	Status	Read only	Read only

10.4 Rotary switch in "SPEED1" or "SPEED2" position

10.4.1 SPEED1 frequency command

Can be set during operation	Leading alphabet	Parameter name	Setting range	Factory default
✓	-	SPEED1 frequency	0.0 Hz ... 500.0 Hz	50.0



The maximum value depends on the value defined by option 3. oF - highest output frequency on [page 78](#).

10.4.2 SPEED1 direction

This parameter determines the direction of SPEED1.

Can be set during operation	Leading alphabet	Parameter name	Setting range	Factory default
-	-	SPEED1 direction	R: Forward L: Reverse	R

10.4.3 SPEED2 frequency command

Can be set during operation	Leading alphabet	Parameter name	Setting range	Factory default
✓	-	SPEED2 frequency	0.0 Hz ... 500.0 Hz	50.0



The maximum value depends on the value defined by option 3. oF - highest output frequency on [page 78](#).

10.4.4 SPEED2 direction

This parameter determines the direction of SPEED2.

Can be set during operation	Leading alphabet	Parameter name	Setting range	Factory default
-	-	SPEED2 direction	R: Forward L: Reverse	L

10.5 Rotary switch in "OPTIONS" position



The following information is relevant for the chapters [10.5.1](#), [10.5.2](#), [10.5.5](#), [10.5.6](#) and [10.5.7](#).

The CONTACTRON Speed Starter controls the motor voltage and frequency in a constant ratio on the output side. This control is called V/f operation. Frequency and voltage are kept proportional to each other up to the rated frequency and voltage of the motor. This is necessary due to the inductive behavior of the motor and leads to a constant torque over wide ranges without overloading the motor in terms of current. To adapt the rated voltage and the rated frequency of the motor, change the values in [10.5.1 "Motor rated frequency"](#) and [10.5.2 "Motor rated voltage"](#). The default value is 50 Hz and 230 V (single phase devices) / 400 V (3-phase devices).

At very low speeds, this mode of operation results in lower torque due to the ohmic resistance of the winding. To increase the torque, adapt the parameters [10.5.6 "Start boost"](#) and [10.5.7 "Voltage lift"](#).

In V/f operation, the speed of the connected motor might vary depending on its load.

10.5.1 Motor rated frequency

Set the rated frequency for the motor as indicated on the motor's nameplate.

Can be set during operation	Leading alphabet	Parameter name	Setting range	Factory default
-	1. rF - motor rated frequency	Motor rated frequency	0.0 Hz ... 500.0 Hz	50.0 Hz

10.5.2 Motor rated voltage

Set this value according to the rated voltage of the motor from the motor's nameplate.



NOTE: Device damage possible

When operating a device with 1-phase mains input with at least 200 V AC, you must not set the motor voltage to 110 V AC in the OPTIONS menu.

Otherwise, the device could be damaged.



When setting 110~120 (220~240) V, half voltage mode will be activated.

Can be set during operation	Leading alphabet	Parameter name	Setting range	Factory default
-	2. rv - motor rated voltage	Motor rated voltage	230 V models: 110 V ... 240 V (1-phase input) 480 V models: 220 V ... 480 V (3-phase input)	230 V AC 400 V AC

10.5.3 Highest output frequency

Set this value to determine the maximum value of SPEED1 and SPPEED2 frequency command.

Can be set during operation	Leading alphabet	Parameter name	Setting range	Factory default
-	3. oF - highest output frequency	Highest output frequency	0.0 Hz ... 500.0 Hz	100.0 Hz

10.5.4 Pulse frequency

With the CONTACTRON Speed Starter the pulse frequency on the output side can be adapted. The device operates with a pulse width modulation. The default value is set to 4 kHz. This frequency can be heard during operation. To reduce the noise the value can be set to 8 kHz, to 16 kHz or to "AUTO".



A higher pulse frequency means a higher derating.

When the pulse frequency is set to "4000, 8000, 16000", the frequency is fixed to the set value.

Can be set during operation	Leading alphabet	Parameter name	Setting range	Factory default
-	4. PF - pulse frequency	Pulse frequency	4000 Hz 8000 Hz 16000 Hz AUTO (16 kHz, 2 kHz ...16 kHz, depending on the rated current)	4000 Hz

When the pulse frequency is set to "AUTO", default is 16 kHz (2 kHz ...16 kHz, depending on the rated current).

If the derating protection is activated, and the operation frequency is larger than the derating curve (as shown in [Figure 10-4 on page 80](#) and [Figure 10-5 on page 80](#)), the rated current is constant, and Pulse Frequency output by the drive decreases automatically according to the ambient temperature, overload output current and overload time.

Figure 10-4 230 V series derating curve (1-phase input)

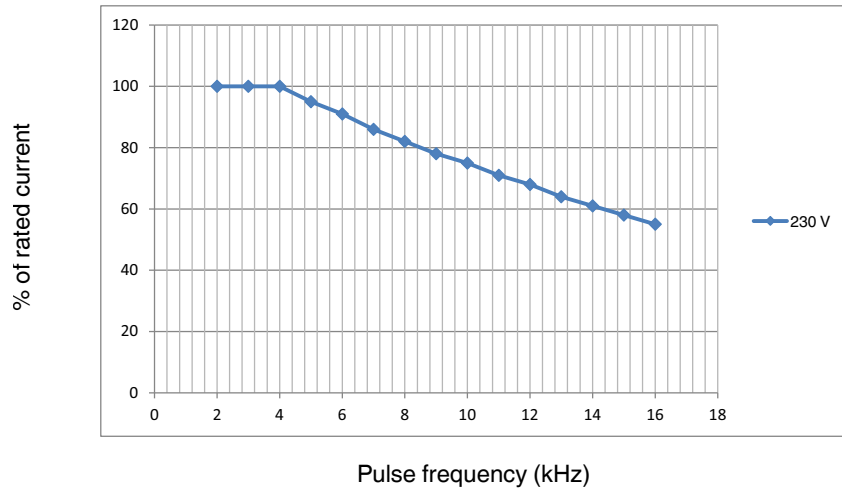
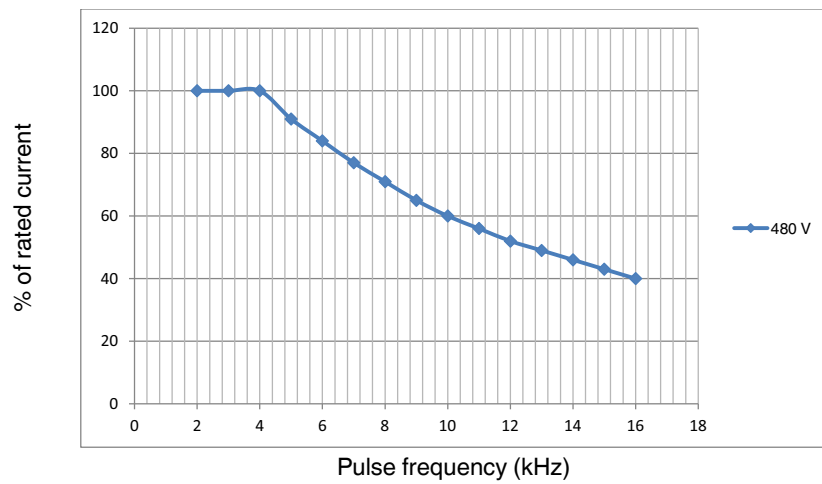

Figure 10-5 480 V series derating curve (3-phase input)



10.5.5 V/F-waveform

Use this parameter to select either a linear V/F curve or a square V/F curve.

When applying a variable loading torque to the asynchronous motor, the loading torque is low at low speed. Decrease the input voltage to reduce the magnetic field of the input current and reduce the flux loss and iron loss to increase efficiency.

If you select square V/F curve, it has lower output torque when motor runs at low speed region. Therefore, rapid acceleration and deceleration is not recommended.

Can be set during operation	Leading alphabet	Parameter name	Setting range	Factory default
✓	5. vF - vF wave form	V/F-waveform	LIn: Linear Sqr: Square	LIn

10.5.6 Start boost

When applying a heavy load to the asynchronous motor, a large portion of output voltage is dropped on the stator-winding resistor with an insufficient air gap magnetic field, which results in excessive output current and insufficient output torque.

In the V/F control application, the output voltage is proportional to the output frequency. In other words, the output voltage is small when the asynchronous motor runs in low speed region. The torque compensation aims to compensate the output torque by increasing the output voltage.

Use this parameter to generate higher output torque. However, when this parameter is set too large, it may cause the motor over-flux, generate large output current and overheating.

Can be set during operation	Leading alphabet	Parameter name	Setting range	Factory default
✓	6. bo - start boost	Start Boost	0 % ... 10.0 %	2.5 %

10.5.7 Voltage lift

Set this parameter to lift the total output voltage. The additional lift voltage is obtained by the product of parameter Voltage Lift and parameter Input Voltage.

The asynchronous motor may vibrate while running if the setting value is too large. Decrease this parameter if the motor starts to vibrate.

Can be set during operation	Leading alphabet	Parameter name	Setting Range	Factory default
✓	7. vL - voltage lift	Voltage Lift	0 % ... 10 %	0 %

10.5.8 Slip compensation

Constant slip is necessary to generate magnetic torque for an asynchronous motor.

In operation, the slip is inverted proportionally to the synchronous speed to generate the same magnetic torque. However, when the synchronous speed is getting lower, the slip is larger.

In another scenario, the slip increases when the load increases.

It also affects the motor speed accuracy.

Use this parameter to set the compensation frequency and reduce the slip to maintain the synchronous speed when the motor runs at the rated current. Set the slip compensation when applying the load or after the acceleration.

Increase the compensation value gradually.

If the actual speed is slower than the reference speed, increase the compensation value. Otherwise, decrease the compensation value

Can be set during operation	Leading alphabet	Parameter name	Setting range	Factory default
✓	8. Sc- slip compensation	Slip compensation	0.0 % ... 10.0 %	0.0 %

10.5.9 PTC

A PTC thermistor on the motor can be connected to the CONTACTRON Speed Starter. This is especially recommended when the device controls the motor with low frequencies. The motor will heat up quicker because the speed is slower and the air flow is smaller. The thermistor detects the temperature of the motor and sends out a warning and error signal as shown below. Connect the thermistor output signal to the CONTACTRON Speed Starter at the input terminals TH1 and TH2.



NOTE:

The CONTACTRON Speed Starter is made according to the Standard IEC/EN 61800-5-1. This means that a reinforced isolation between the power circuit and the lower voltage is needed. Therefore the thermistor in the motor needs a reinforced isolation in order to not weaken the complete isolation system of the application.

Alternatively, an external signal conditioner can be used between the CONTACTRON Speed Starter and the thermistor of the motor. In this case a signal conditioner with the overvoltage category 3 needs to be used.

Protection level is shown as below:

1. PTC input voltage >9.99 V, short failure
2. PTC input voltage \geq 9.25 V, normal operation
3. PTC input voltage \leq 8.74 V, overheat warning
4. PTC input voltage \leq 8.43 V, overheat error
5. PTC input voltage \leq 2.5 V, open loop

Can be set during operation	Leading alphabet	Parameter name	Setting range	Factory default
✓	9. PTC - PTC active	PTC	No: disabled Yes: enabled	No

10.5.10 Parameter lock

Use this parameter to prevent personnel from setting other parameters by accident.

Can be set during operation	Leading alphabet	Parameter name	Setting range	Factory default
✓	10. PL - parameter lock	Parameter lock	No: unlock the parameter protection and set the parameters Yes: all parameters are read only	No

10.5.11 Parameter reset

Return all parameters to defaults.

Can be set during operation	Leading alphabet	Parameter name	Setting range	Factory default
-	11.res - parameter reset	Parameter reset	No: No function Yes: Returns parameters to default	No

10.5.12 Identity code

The first digit is defined as 230 V models one-phase or 480 V models three-phase.

The second to fourth digits represent the power of CONTACTRON Speed Starter.

The last digit represents model of CONTACTRON Speed Starter: Normal, with EMC filter.

Can be set during operation	Leading alphabet	Parameter name	Setting range	Factory default
-	12. ID - identity code	Identity code	Read only	Read only

Example: 230 V models 0.25 kW with EMC filter is displayed as 1.0.25.E

Figure 10-6 Example identity code

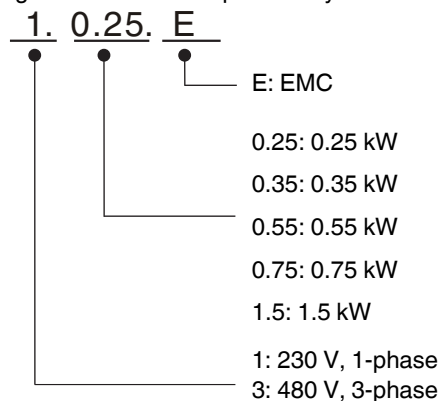

10.5.13 Firmware version

Can be set during operation	Leading alphabet	Parameter name	Setting range	Factory default
-	13.ver - firmware version	Firmware version	Read only	Read only

10.5.14 Relay output

Use this parameter to set the active condition of the relay output terminals.

Can be set during operation	Leading alphabet	Parameter name	Setting range	Factory default
✓	14. FC - feedback contact	Relay output	Warn: Just the warnings Error: Just the errors Both: Errors and warnings	Both

11 Warning Codes

If a warning is shown on the device, the PWR/STO/ERR LED is flashing red. In case of a STO warning, the PWR/STO/ERR LED is flashing green.

ID	Display on control panel	Warning name	Description
1	UV - under voltage warning	Under voltage (UV)	DC link circuit under warning level
Warning and reset			
Warning condition		230 V AC models: 150 V AC ... 240 V AC input: <195 V DC 110 V AC ... 149 V AC input: <100 V DC 480 V AC models: 300 V AC ... 480 V AC: <390 V DC 220 V AC ... 299 V AC: <195 V DC	
Warning time		Immediately act when the DC link circuit voltage is lower than the level	
Reset method		Auto	
Reset condition		Automatically reset when the DC link circuit voltage is higher than the reset level 230 V AC models: 150 V AC ... 240 V AC input: >210 V DC 110 V AC ... 149 V AC input: >105 V DC 480 V AC models: 300 V AC ... 480 V AC: >420 V DC 220 V AC ... 299 V AC: >210 V DC	
Cause		Corrective actions	
Power-off		Improve power supply condition.	
Power voltage changes		Adjust voltage to the CONTACTRON Speed Starter's setting power range	
Start up the motor with large capacity		Check the power system. Increase the capacity of power equipment.	
The load is too large		Reduce the load. Increase the CONTACTRON Speed Starter capacity. Increase the acceleration time.	

CONTACTRON Speed Starter

ID	Display on control panel	Warning name	Description
2	OV - over voltage warning	Over voltage (OV)	DC link circuit over warning level
Warning and reset			
Warning condition		230 V models: >375 V DC 480 V models: >750 V DC	
Warning time		Immediately act when the DC link circuit voltage is higher than the level	
Reset method		Auto	
Reset condition		Automatically reset when the DC link circuit voltage is lower than the reset level 230 V AC models: <360 V DC 480 V AC models: <720 V DC	
Cause		Corrective actions	
Deceleration time is too short, causing too large regenerative energy of the load.		Increase the setting value for Parameter Ramp time Replace the CONTACTRON Speed Starter with a larger capacity model.	
Power voltage is too high		Check if the input voltage is within the rated CONTACTRON Speed Starter input voltage range, and check for possible voltage spikes.	
Motor ground fault		The ground short circuit current charges the capacitor in the main circuit through the power. Check if there is ground fault on the motor cable, wiring box and its internal terminals. Troubleshoot the ground fault.	

ID	Display on control panel	Warning name	Description
3	STO - STO warning	Safe Torque Off (STO)	STO function active
Warning and reset			
Warning condition		Hardware detection	
Warning time		Immediately act	
Reset method		Auto	Reconnect STO+ to 24V terminal and STO- to GND terminal. Afterwards, it automatically resets.
Reset condition		Reset only after STO warning is cleared.	
Cause		Corrective actions	
No connection of the STO+ to 24V terminal and/or STO- to GND terminal when motor is at standby or RUN.		Check if the STO+ is connected to 24V terminal and STO- to GND terminal.	

ID	Display on control panel	Warning name	Description
4	OT - over temperature warning	Over temperature warning (ot)	Over temperature (PTC), when parameter PTC is set to enable.
Warning and reset			
Warning condition		PTC input voltage is ≤ 8.74 V	
Warning time		Immediately act	
Reset method		Auto	
Reset condition		Reset when the input voltage is higher than reset level: ≥ 9.25 V and < 9.99 V	
Cause		Corrective actions	
Motor blocked		Clear the motor blocking.	
The load is too large		Decrease the loading. Replace with a motor with a larger power.	
Ambient temperature is too high		Change the installed place if there are heating devices in the surroundings. Install / add cooling fans or air conditioner to lower the ambient temperature.	
Motor cooling system fault		Check the cooling system and clear the fault if there is any.	
Motor fan error		Replace the fan.	

12 Error codes

If an error is shown on the device, the PWR/STO/ERR LED is flashing red.

If an internal error is shown on the device, the red PWR/STO/ERR LED is permanently on.

In case of a reset press [SET / RESET] or activate the RESET input for 0.5 s ... 3 s to acknowledge the error.

The error codes and the corrective actions are listed below.

ID	Display on control panel	Fault name	Fault descriptions
1	PHL - phase loss protection	Phase loss protection (PHL)	Phase loss of power input
Reset			
Reset method		Manual reset	
Reset condition		Reset after the fault is cleared	
Cause		Corrective actions	
Mains phase failure		Check wiring of the mains connection. Check fuses.	

CONTACTRON Speed Starter

ID	Display on control panel	Fault name	Fault descriptions
2	UV - Under voltage error	Undervoltage (UV)	DC link voltage is lower than safe operating voltage
Reset			
Reset method		Manual reset	
Reset condition		Reset is possible after the DC link voltage is higher than the following values. 230 V AC models: 150 V AC ... 240 V AC input: >210 V DC 110 V AC ... 149 V AC input: >105 V DC 480 V AC models: 300 V AC ... 480 V AC: >420 V DC 220 V AC ... 299 V AC: >210 V DC	
Cause		Corrective actions	
Power-off		Improve power supply condition.	
Power voltage changes		Adjust voltage of the CONTACTRON Speed Starter's setting power range	
Start up the motor with large capacity		Check the power system. Increase the capacity of power equipment.	
The load is too large		Reduce the load. Increase the CONTACTRON Speed Starter capacity. Increase the acceleration time.	

ID	Display on control panel	Fault name	Fault descriptions
3	OV - Over voltage error	Overvoltage (ov)	DC link voltage has exceeded the threshold for overvoltage.
Reset			
Reset method		Manual reset	
Reset condition		Reset only when the DC link voltage is lower than the reset level: 230 V AC models: 150 V AC ... 240 V AC input: >210 V DC 110 V AC ... 149 V AC input: >105 V DC 480 V AC models: 300 V AC ... 480 V AC: >420 V DC 220 V AC ... 299 V AC: >210 V DC	
Cause		Corrective actions	
Deceleration time is too short, causing too large regenerative energy of the load.		Increase the "RAMP" time. Replace the CONTACTRON Speed Starter with a larger capacity model.	
Mains voltage is too high		Check mains voltage.	

CONTACTRON Speed Starter

ID	Display on control panel	Fault name	Fault descriptions
5	I2t 1 - Motor overload error at Speed1	Motor overload (I ² t 1)	Motor is thermically overloaded. The error occurred during SPEED1/2 control.
6	I2t 2 - Motor overload error at Speed2	(I ² t 2)	
Reset			
Reset method		Manual reset after 5 s possible.	
Cause		Corrective actions	
The load is too large.		Check the motor data and the current setting. Check the motor and the mechanics.	
Acceleration / deceleration time and the working cycle are too short.		Increase the setting values for parameter Ramp time	

ID	Display on control panel	Fault name	Fault descriptions
7	Olsp1 - Device overload error at Speed1	Overload Speed Starter Speed1 (oLSP1)	The CONTACTRON Speed Starter detects excessive output current at Speed1/2
8	Olsp2 - Device overload error at Speed2	Overload Speed Starter Speed 2 (oLSP2)	
Reset			
Reset method		Manual reset	
Cause		Corrective actions	
The load is too heavy		Reduce the load Use a device with a higher power class	
Ramp time is too short		Turn the rotary switch to RAMP page to increase the setting value.	
The power class of the CONTACTRON Speed Starter is too small		Check the drive design Use a device with a higher power class	
Overload during low-speed operation		Reduce the load during low-speed operation. Use a device with a higher power class. Decrease the carrier frequency of parameter Pulse Frequency.	
Torque compensation is too large		Decrease torque compensation gain (refer to parameter "Start boost" on page 81 and "Voltage lift" on page 81) until the output current reduces and the motor does not stall.	

Figure 12-1 Overload capacity

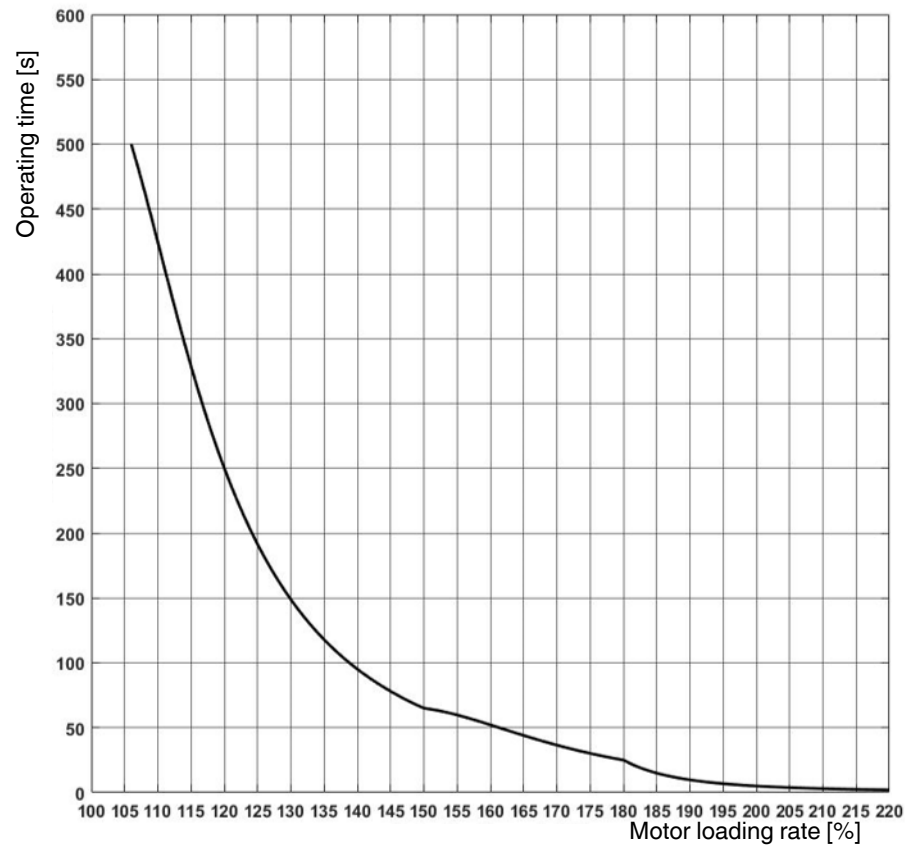

CONTACTRON Speed Starter

ID	Display on control panel	Fault name	Fault descriptions
9	loSP1 - Device over current error at Speed1	CONTACTRON Speed Starter Overcurrent Speed 1 (IoSP1)	Output current is 300% of the rated device current at Speed1/2
10	loSP1 - Device over current error at Speed2	CONTACTRON Speed Starter Overcurrent Speed 2 (IoSP2)	
Reset			
Reset method		Manual reset	
Cause		Corrective actions	
Ramp time is too short		Increase the ramp time.	
Impulsive change of the load		Reduce the load or increase the capacity of the CONTACTRON Speed Starter	
The load is too large.		<p>Check if the output current during the whole working process exceeds the CONTACTRON Speed Starter's rated current. If yes, replace the CONTACTRON Speed Starter with a larger capacity model.</p> <p>Check drive layout.</p> <p>Check settings "Voltage lift" on page 81, "V/F-waveform" on page 81, "Start boost" on page 81</p>	

ID	Display on control panel	Fault name	Fault descriptions
11	OL3 - Power component overload error	CONTACTRON Speed Starter's power components overload (oL3)	The internal power components of the CONTACTRON Speed Starter reaches the overload protection level.
Reset			
Action time		Immediately act	
Reset method		Manual reset	
Reset condition		Reset after the fault is cleared	
Cause		Corrective actions	
CONTACTRON Speed Starter's power components overload		<p>Enhance the heat dissipation capacity for the cabinet.</p> <p>Lower the pulse frequency (refer to parameter "Pulse frequency" on page 79).</p> <p>Replace the CONTACTRON Speed Starter with a larger power model.</p>	

ID	Display on control panel	Fault name	Fault descriptions
12	Hot - IGBT over temperature	IGBT overheating (Hot)	Maximum IGBT temperature is exceeded
Reset			
Reset method		Manual reset	
Reset condition		Reset only when the IGBT temperature is <70 °C	
Cause		Corrective actions	
Check if the ambient temperature or temperature inside the control cabinet is too high, or if there is obstruction in the ventilation hole of the control cabinet.		<p>Check ambient temperature.</p> <p>Regularly inspect the ventilation hole of the control cabinet.</p> <p>Change the installed place if there are heating objects in the surroundings.</p> <p>Install / add cooling fan or air conditioner to lower the temperature inside the cabinet.</p>	
Check if there is any obstruction on the heat sink or if the fan is running.		Remove the obstruction or replace the cooling fan.	
Insufficient ventilation space		Increase ventilation space of the CONTACTRON Speed Starter.	
Check if the CONTACTRON Speed Starter matches the corresponding load.		<p>Reduce the load.</p> <p>Reduce the pulse frequency.</p> <p>Replace the CONTACTRON Speed Starter with a larger power class.</p>	

CONTACTRON Speed Starter

ID	Display on control panel	Fault name	Fault descriptions
13	Th1o - Temperature detection error	IGBT temperature detection failure (tH1o)	IGBT hardware cannot detect the temperature anymore.
Reset			
Reset method		Manual reset	
Cause		Corrective actions	
Hardware failure		Return to the factory for repair.	
System is operated below -20 °C		Check environmental conditions	

ID	Display on control panel	Fault name	Fault descriptions
14	Ot - PTC over temperature	Over temperature (ot)	Over temperature (PTC), when parameter PTC is enabled. The PTC input voltage is ≤ 8.43 V.
Reset			
Reset method		Manual	
Reset condition		Reset when input voltage is ≥ 9.25 V	
Cause		Corrective actions	
Motor shaft lock		Remove the shaft lock. Check drive layout. Check the mechanics of the motor.	
The load is too large		Reduce the load. Increase the motor capacity. Check drive layout. Check the mechanics of the drive system.	
Ambient temperature of the motor is too high.		Change the installed place if there are heating devices in the surroundings. Install / add cooling fan or air conditioner to lower the ambient temperature.	
Motor cooling system fault		Check the cooling system to clear the fault if there is any.	

ID	Display on control panel	Fault Name	Fault descriptions
15	PTCsc - PTC short circuit	PTC short circuit (PTCSC)	PTC short circuit, or under temperature, when parameter PTC is set to enable. Analog input voltage is >9.99 V
Reset			
Reset method		Manual	
Reset condition		Reset when input voltage is lower than warning condition.	
Cause		Corrective actions	
Faulty wiring of the PTC.		Check the wiring of the PTC.	

ID	Display on control panel	Fault name	Fault descriptions
16	PTCo - PTC open	PTC Open (PTCO)	PTC wire break, when parameter PTC is enabled. PTC input voltage is ≤ 2.5 V
Reset			
Reset method		Manual	
Reset condition		Reset when input voltage is ≥ 9.25 V	
Cause		Corrective actions	
Faulty wiring of the PTC.		Check the wiring of the PTC.	

CONTACTRON Speed Starter

ID	Display on control panel	Fault name	Fault descriptions
17	GFF - Ground fault	Ground fault (GFF)	The CONTACTRON Speed Starter detects an unbalanced three-phase current.
Reset			
Reset method		Manual reset	
Cause		Corrective actions	
Motor burnout or aging insulation occurred		Check the motor insulation value with a suitable measuring device. Replace the motor if the insulation is poor. Check the cabling of the motor.	

ID	Display on control panel	Fault name	Fault descriptions
18	U-V - Short circuit U-V	Phase UV Short (U-V)	Short-circuit has been detected between U and V output terminals before the motor starts.
Reset			
Reset method		Manual reset	
Cause		Corrective actions	
Short-circuit of motor wiring		Check the motor wiring if there is a short-circuit	

ID	Display on control panel	Fault name	Fault descriptions
19	U-W - Short circuit U-W	Phase UW Short (U-W)	Short-circuit is detected between U and W output terminals before the motor starts.
Reset			
Reset method		Manual reset	
Cause		Corrective actions	
Short-circuit of motor wiring		Check the motor wiring if there is a short-circuit	

ID	Display on control panel	Fault name	Fault descriptions
21	V-W - Short circuit V-W	Phase VW Short (V-W)	Short-circuit is detected between V and W output terminals before the motor starts.
Reset			
Reset method		Manual reset	
Cause		Corrective actions	
Short-circuit of motor wiring		Check the motor wiring if there is a short-circuit	

ID	Display on control panel	Fault name	Fault descriptions
22	OPL - Output phase loss	Output phase loss (OPL)	Output phase loss
Reset			
Reset method		Manual reset	
Cause		Corrective actions	
Unbalanced three-phase impedance of the motor		Replace the motor.	
The motor is wired incorrectly		Check the wire connection between CONTACTRON Speed Starter output terminal and motor.	

ID	Display on control panel	Fault name	Fault descriptions
23	cf3 - Error-hardware check	Hardware check (CF3)	Failure has been detected on the CONTACTRON Speed Starter's control board
Reset			
Reset method		No	
Cause		Corrective actions	
Hardware failure		Return the CONTACTRON Speed Starter to the factory for repair.	

ID	Display on control panel	Fault name	Fault descriptions
24	cf2 - Error-firmware check	EEPROM read error (CF2)	Internal EEPROM cannot be read.
Reset			
Reset method		Manual reset	
Cause		Corrective actions	
Internal EEPROM cannot be read.		If the failure still exists after a reset return the CONTACTRON Speed Starter to the factory for repair.	

CONTACTRON Speed Starter

ID	Display on control panel	Fault name	Fault descriptions
25	RESET - Parameter reset	Parameters reset (reset)	Parameters resets to default value.
Reset			
Reset method		Manual reset	
Cause		Corrective actions	
Factory reset activated		Press [SET / RESET] to clear the default warning code.	

ID	Display on control panel	Fault name	Fault descriptions
26	STO1 - STO channel 1 error	STO CH1 error (STO1)	STO channel 1 internal error.
Reset			
Reset method		No	
Cause		Corrective actions	
Hardware failure		Return the CONTACTRON Speed Starter to the factory for repair.	

ID	Display on control panel	Fault name	Fault descriptions
27	STO2 - STO channel 2 error	STO CH2 error (STO2)	STO channel 2 internal error
Reset			
Reset method		No	
Cause		Corrective actions	
Hardware failure		Return the CONTACTRON Speed Starter to the factory for repair.	

13 STO - Safe Torque Off

13.1 Defined safety function

**NOTE:**

The factory default STO bridge is installed between 24 V OUT to STO+ and GND to STO-. When using the safety function, remove this bridge.

The 24 V OUT (and GND) is for STO only. Do not use it for other purposes.

The safety function is defined as the shut down of a motor as soon as there is no 24V-signal on STO+ or no GND-signal on STO-.

If you activate the safety function STO the motor is not galvanically isolated (electrical safety).

The Safe Torque Off function complies with the following international standards:

- EN ISO 13849-1: Category 4 PL e
- IEC 61508: SIL 3
- IEC/EN 61800-5-2: SIL 3
- IEC 60204-1: Category 0
- IEC/EN 61800-5-2: safety standard for drives

13.2 Safety information

- The safety function must be requested once every 24 hours in order to comply with Category 4 PL e safety integrity.
- The safety function must be requested once every 3 months in order to comply with the safety integrity of Category 3 PL e.
- The safety function must be requested once every year in order to comply with the safety integrity of Category 3 PL d.
- An inadmissible restart may occur after removal of the STO function. This must be blocked by a higher-level safety system.
- A double failure may result in an unintentional jerk. The angle of rotation depends on the number of poles of the selected drive and on the gear ratio of the selected gearbox.
- The device may not be exposed to mechanical or thermal influences that exceed the limits as described in the operating instructions. To protect against mechanical or electrical damage, install the device in an appropriate housing with a suitable degree of protection (minimum IP54) in accordance with IEC/EN 60529.
- For the STO+ and STO- inputs, suitably insulated fixed wires or stranded wires with end ferrules have to be used.
- The requirements of IEC/EN 61800-5-2 must be observed in order to reliably exclude short circuits and cross-connections of the safety-relevant cables.
- Only qualified personnel may install and commission safety technology.
- The inputs STO+ and STO- may only be operated from a single SELV/PELV 24 V supply.
- The maximum length and the maximum frequency of the light and dark test impulses are defined in [Table A-4 "Digital input \(STO+ / STO-\)"](#)
- Electrical parameters see [Table A-4 "Digital input \(STO+ / STO-\)"](#)

13.3 STO input

In order to operate the motor that is connected to the CONTACTRON Speed Starter, you must issue the release to the device via the STO input.

As soon as a valid signal is applied to the STO input (terminals STO+ and STO-), the device receives control commands and the motor can be operated.

With non-safety-related applications, you can also issue the release by bridging terminals (STO-) and (GND) and terminals (STO+) and (24V OUT).

13.4 Safety parameters

Table 13-1 System conditions

Specification	Parameter
Database for failure rates	SN 29500
Stop category [IEC/EN 60204-1]	0
Ambient temperature [°C]	50

Table 13-2 Safety parameters for EN ISO 13849-1

Specification	Parameter
Performance Level	e
Category	4
MTTF _d [years]	399
DC _{avg} [%] - diagnostic coverage	high (>99)

Table 13-3 Safety parameters for IEC 61508, Part 1-7 and IEC/EN 62061 - high demand

Specification	Parameter
System type (consisting of subsystems)	Type A
SIL	3
SILCL	3
HFT - Hardware failure tolerance	1
SFF [%] - Safe failure fraction	99.9
DC [%] - diagnostic coverage	99.9
PFH [1/h] - probability of a dangerous failure per hour	$10.9 * 10^{-12}$
Mission time [years]	20

14 Application notes

14.1 Application examples without STO function

14.1.1 1-phase

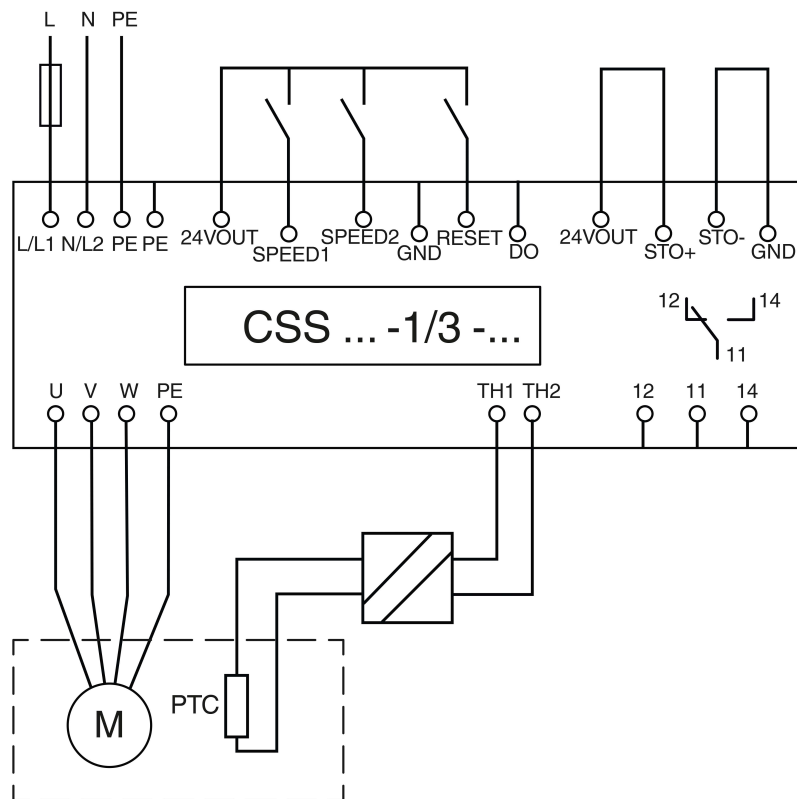

14.1.2 3-phase

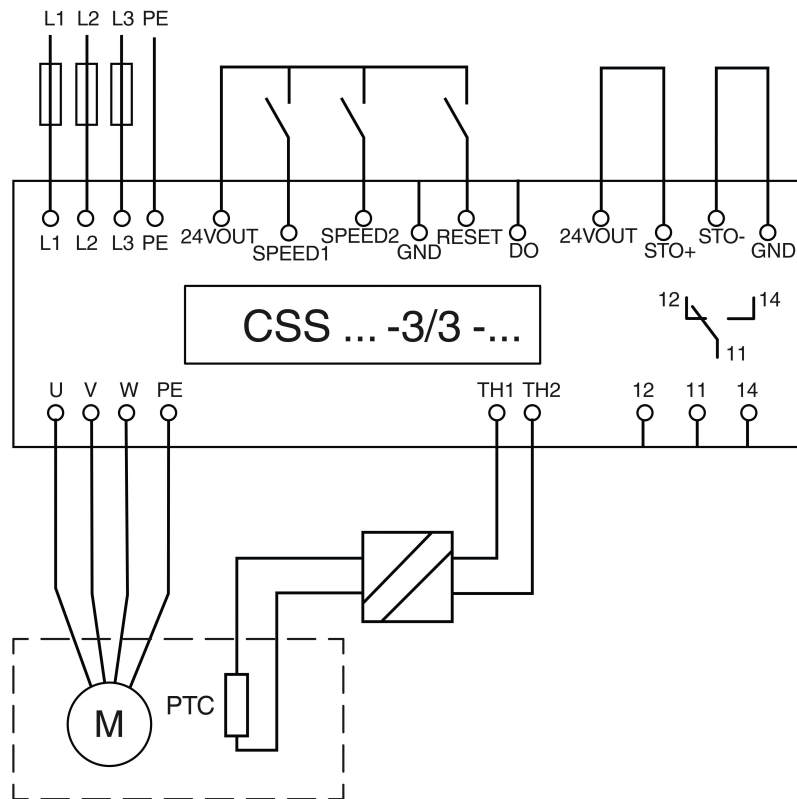

14.2 Application examples with STO function

Figure 14-1 Safe shutdown 2-channel

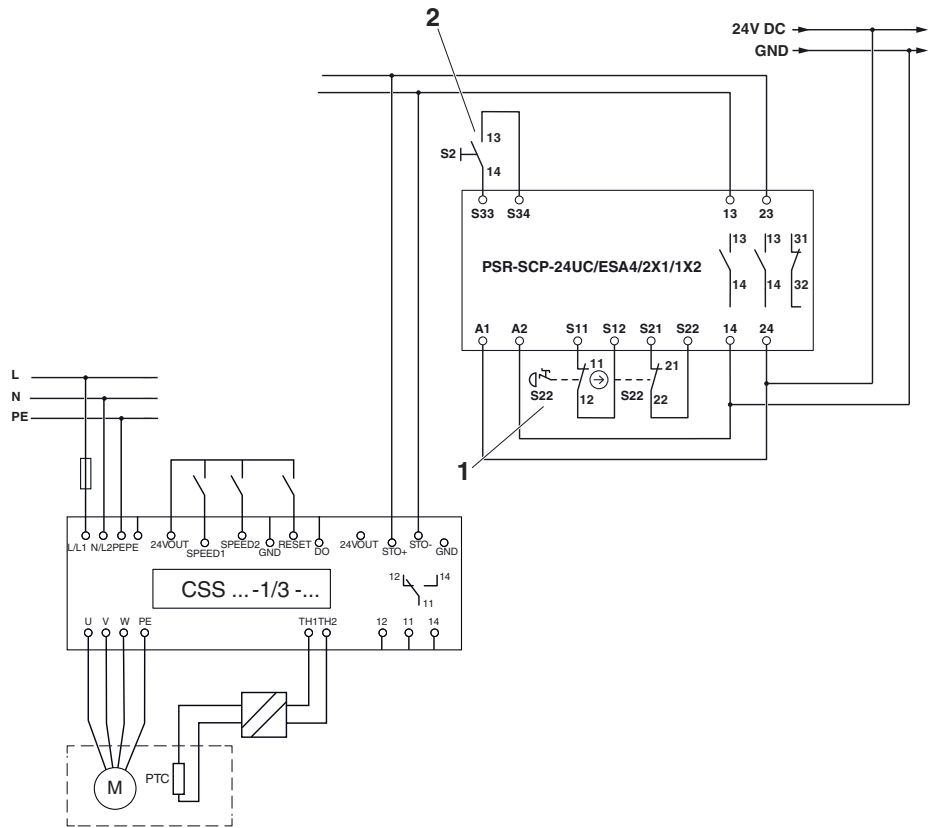

- 1 Emergency stop
- 2 Reset button

Figure 14-2 Safe shutdown 1-channel (STO+)

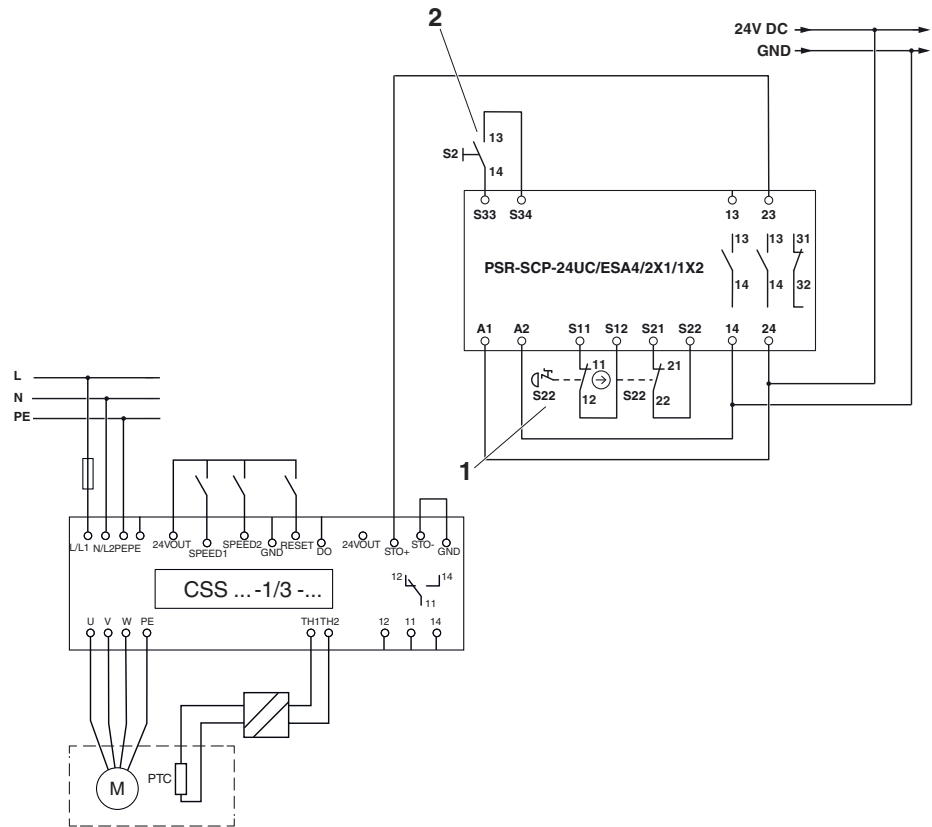

- 1 Emergency stop
- 2 Reset button

Figure 14-3 Safe shutdown 1-channel (STO-)

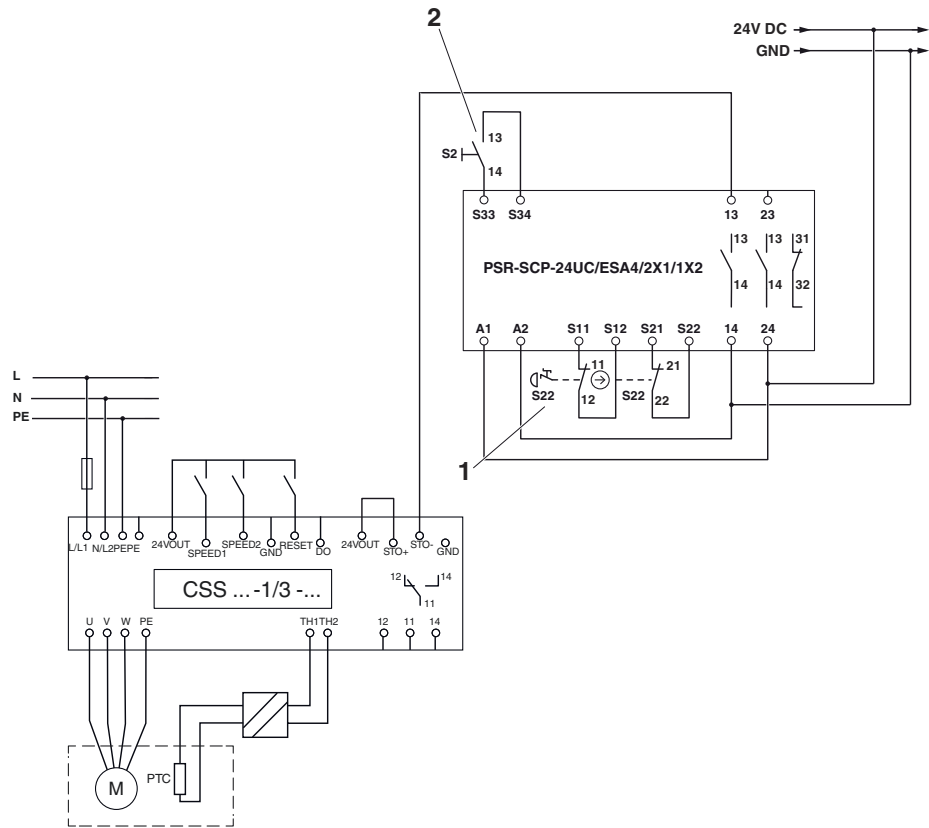

- 1 Emergency stop
- 2 Reset button

14.3 Block diagram

14.3.1 1-phase

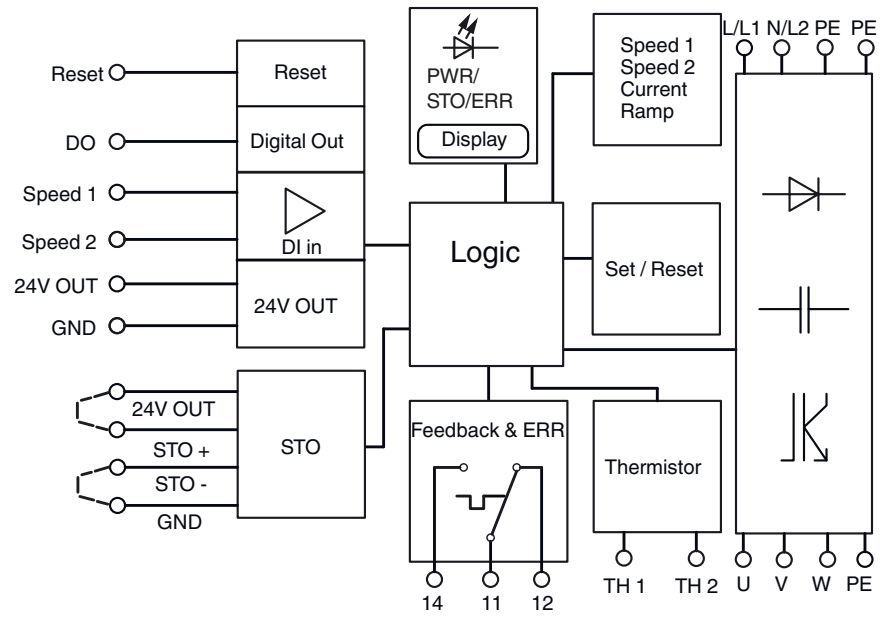

14.3.2 3-phase

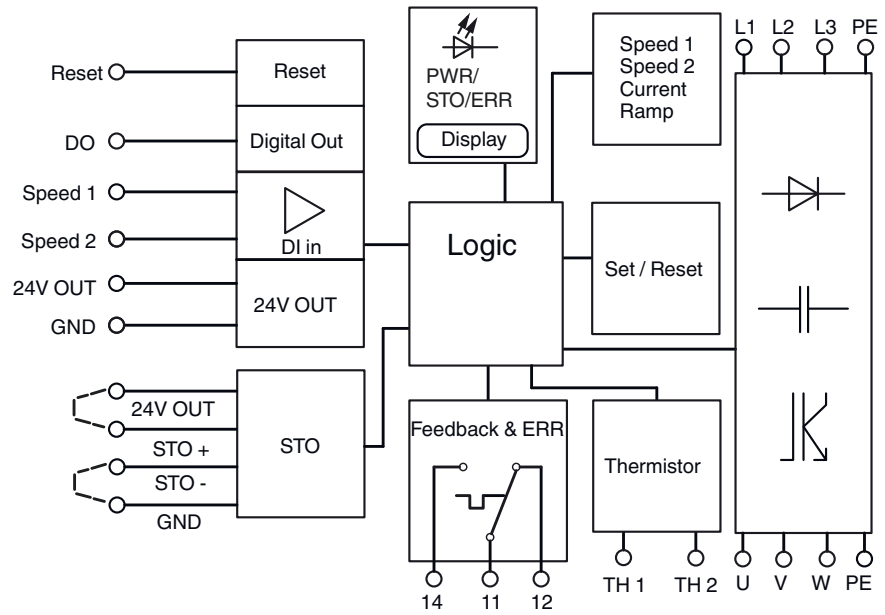

A Technical data

A 1 230 V models

A 1.1 230V models 1-phase (without built-in EMC filter)

Frame	A1		B1		
MODEL CSS ___-1/3	0.25	0.37	0.55	0.75	1.5
Rated power [kW/HP]	0.25/0.33	0.37/0.5	0.55/0.75	0.75/1.0	1.5/ 2.0
Apparent output power [kVA]	0.7	1.0	1.3	1.7	3.0
Mains rated input voltage [V AC]	1-phase 230 / 240				
Mains input voltage range [V AC]	110 V AC ... 240 V AC (-15 % / +10 %)				
Mains frequency range [Hz]	47 ... 63				
Rated mains current [A]					
Without mains choke	3.5	5.3	6.7	9.1	15.8
With mains choke	3.3	4.8	6.2	8.3	14.5
Rated output current [A]					
@ 4 kHz	1.7	2.5	3.2	4.3	7.5
@ 8 kHz	1.4	2.1	2.6	3.5	6.2
@ 16 kHz	0.9	1.4	1.8	2.4	4.1
Output frequency range [Hz]	0.0 ... 500.0				
Power loss [W]					
@ 2 kHz	18	22	29	37	67
@ 4 kHz	21	26	33	42	74
@ 8 kHz	20	24	32	40	70
@ 16 kHz	19	23	30	38	66
at inverter disable	9	9	9	9	9
Overcurrent cycle 180 s					
Max. output current (150 % rated mains current) [A]	2.55	3.75	4.8	6.45	11.25
Overload time [s]	30	30	30	30	30
Recovery time [s]	150	150	150	150	150
Max. output current during the recovery time (75 % rated mains current) [A]	1.275	1.875	2.4	3.225	5.625

CONTACTRON Speed Starter

Frame	A1		B1		
MODEL CSS _ _ _ -1/3	0.25	0.37	0.55	0.75	1.5
Overcurrent cycle 15 s					
Max. output current (180 % rated mains current) [A]	3.06	4.5	5.76	7.74	13.5
Overload time [s]	3	3	3	3	3
Recovery time [s]	12	12	12	12	12
Max. output current during the recovery time (50 % rated mains current) [A]	0.85	1.25	1.6	2.15	3.75
Cycle mains switching [per minute]	1	1	1	1	1
Discharge time (DC link capacitors) [min]	3	3	3	3	3
Dimensions [width x height x depth mm]					
With mounting brackets	35 x 210 x 174.7		45 x 210 x 189.7		
Without mounting brackets and rotary switch	35 x 180 x 165		45 x 180 x 180		
Cooling method	Heat sink			Fan cooling	
Maximum motor cable length [m]					
EMC Compliance Category C2	50	50	50	50	50
EMC Compliance Category C3	50	50	50	50	50
Without EMC Compliance	50	50	50	50	50

A 1.2 230V models 1-phase (with built-in filter)

Frame	A2		B2		
MODEL CSS _ _ _ -1/3-EMC	0.25	0.37	0.55	0.75	1.5
Rated power [kW/HP]	0.25/0.33	0.37/0.5	0.55/0.75	0.75/1.0	1.5/ 2.0
Apparent output power [kVA]	0.7	1.0	1.3	1.7	3.0
Mains rated input voltage [V AC]	1-phase 230 / 240				
Mains input voltage range [V AC]	110 V AC ... 240 V AC (-15 % / +10 %)				
Mains frequency range [Hz]	47 ... 63				
Rated mains current [A]					
Without mains choke	3.5	5.3	6.7	9.1	15.8
With mains choke	3.3	4.8	6.2	8.3	14.5
Rated output current [A]					
@ 4 kHz	1.7	2.5	3.2	4.3	7.5
@ 8 kHz	1.4	2.1	2.6	3.5	6.2
@ 16 kHz	0.9	1.4	1.8	2.4	4.1
Output frequency range [Hz]	0.0 ... 500.0				
Power loss [W]					
@ 2 kHz	20	24	31	38	69
@ 4 kHz	23	27	35	43	75
@ 8 kHz	22	26	33	41	71
@ 16 kHz	21	25	32	39	67
at inverter disable	9	9	9	9	9
Overcurrent cycle 180 s					
Max. output current (150 % rated mains current) [A]	2.55	3.75	4.8	6.45	11.25
Overload time [s]	30	30	30	30	30
Recovery time [s]	150	150	150	150	150
Max. output current during the recovery time (75 % rated mains current) [A]	1.275	1.875	2.4	3.225	5.625
Overcurrent cycle 15 s					
Max. output current (180 % rated mains current) [A]	3.06	4.5	5.76	7.74	13.5
Overload time [s]	3	3	3	3	3
Recovery time [s]	12	12	12	12	12
Max. output current during the recovery time (50 % rated mains current) [A]	0.85	1.25	1.6	2.15	3.75
Cycle mains switching [per minute]	1	1	1	1	1
Discharge time (DC link capacitors) [min]	3	3	3	3	3

CONTACTRON Speed Starter

Frame	A2		B2		
MODEL CSS _ _ _-1/3-EMC	0.25	0.37	0.55	0.75	1.5
Dimensions [width x height x depth mm]					
With mounting brackets	35 x 210 x 174.7		45 x 210 x 189.7		
Without mounting brackets and rotary switch	35 x 180 x 165		45 x 180 x 180		
Cooling method	Heat sink			Fan cooling	
Maximum motor cable length [m]					
EMC Compliance Category C2	20	20	20	20	20
EMC Compliance Category C3	20	20	20	20	20
Without EMC Compliance	50	50	50	50	50

A 2 480 V models

A 2.1 480V models 3-phase (without built-in EMC filter)

Frame	A1			B1	
MODEL CSS ___-3/3	0.25	0.37	0.55	0.75	1.5
Rated power [kW/HP]	0.25/0.33	0.37/0.5	0.55/0.75	0.75/1.0	1.5/ 2.0
Apparent output power [kVA]	0.6	1.0	1.2	1.7	2.7
Mains rated input voltage [V AC]	3-phase 380 / 400 / 480				
Mains input voltage range [V AC]	220 V AC ... 480 V AC (-15 % / +10 %)				
Mains frequency range [Hz]	47 ... 63				
Rated mains current [A]					
Without mains choke	1.0	1.7	2.0	2.8	4.2
With mains choke	0.9	1.5	1.8	2.4	3.8
Rated output current [A]					
@ 4 kHz	0.9	1.5	1.8	2.5	3.9
@ 8 kHz	0.6	1.1	1.3	1.8	2.8
@ 16 kHz	0.4	0.6	0.7	1.0	1.6
Output frequency range [Hz]	0.0 ... 500.0				
Power loss [W]					
@ 2 kHz	14	17	22	28	50
@ 4 kHz	18	22	27	34	58
@ 8 kHz	18	21	26	32	55
@ 16 kHz	17	20	25	31	53
at inverter disable	9	9	9	9	9
Overcurrent cycle 180 s					
Max. output current (150 % rated mains current) [A]	1.35	2.25	2.7	3.75	5.85
Overload time [s]	30	30	30	30	30
Recovery time [s]	150	150	150	150	150
Max. output current during the recovery time (75 % rated mains current) [A]	0.675	1.125	1.35	1.875	2.925
Overcurrent cycle 15 s					
Max. output current (180 % rated mains current) [A]	1.62	2.7	3.24	4.5	7.02
Overload time [s]	3	3	3	3	3
Recovery time [s]	12	12	12	12	12
Max. output current during the recovery time (50 % rated mains current) [A]	0.45	0.75	0.9	1.25	1.95
Cycle mains switching [per minute]	1	1	1	1	1
Discharge time (DC link capacitors) [min]	3	3	3	3	3

CONTACTRON Speed Starter

Frame	A1			B1	
MODEL CSS _ _ _-3/3	0.25	0.37	0.55	0.75	1.5
Dimensions [width x height x depth mm]					
With mounting brackets	35 x 210 x 174.7			45 x 210 x 189.7	
Without mounting brackets and rotary switch	35 x 180 x 165			45 x 180 x 180	
Cooling method	Heat sink			Fan cooling	
Maximum motor cable length [m]					
EMC Compliance Category C2	50	50	50	50	50
EMC Compliance Category C3	50	50	50	50	50
Without EMC Compliance	50	50	50	50	50

A 2.2 480 V models 3-phase (with built-in EMC filter)

Frame	A2				B2
MODEL CSS _ _ _-3/3-EMC	0.25	0.37	0.55	0.75	1.5
Rated power [kW/HP]	0.25/0.33	0.37/0.5	0.55/0.75	0.75/1.0	1.5/ 2.0
Apparent output power [kVA]	0.6	1.0	1.2	1.7	2.7
Mains rated input voltage [V AC]	3-phase 380 / 400 / 480				
Mains input voltage range [V AC]	220 V AC ... 480 V AC (-15 % / +10 %)				
Mains frequency range [Hz]	47 ... 63				
Rated mains current [A]					
Without mains choke	1.0	1.7	2.0	2.8	4.2
With mains choke	0.9	1.5	1.8	2.4	3.8
Rated output current [A]					
@ 4 kHz	0.9	1.5	1.8	2.5	3.9
@ 8 kHz	0.6	1.1	1.3	1.8	2.8
@ 16 kHz	0.4	0.6	0.7	1.0	1.6
Output frequency range [Hz]	0.0 ... 500.0				
Power loss [W]					
@ 2 kHz	16	19	24	29	51
@ 4 kHz	20	23	29	36	59
@ 8 kHz	19	23	28	34	56
@ 16 kHz	19	22	27	32	54
at inverter disable	9	9	9	9	9
Overcurrent cycle 180 s					
Max. output current (150 % rated mains current) [A]	1.35	2.25	2.7	3.75	5.85
Overload time [s]	30	30	30	30	30
Recovery time [s]	150	150	150	150	150
Max. output current during the recovery time (75 % rated mains current) [A]	0.675	1.125	1.35	1.875	2.925
Overcurrent cycle 15 s					
Max. output current (180 % rated mains current) [A]	1.62	2.7	3.24	4.5	7.02
Overload time [s]	3	3	3	3	3
Recovery time [s]	12	12	12	12	12
Max. output current during the recovery time (50 % rated mains current) [A]	0.45	0.75	0.9	1.25	1.95
Cycle mains switching [per minute]	1	1	1	1	1
Discharge time (DC link capacitors) [min]	3	3	3	3	3

CONTACTRON Speed Starter

Frame	A2				B2
MODEL CSS _ _ _-3/3-EMC	0.25	0.37	0.55	0.75	1.5
Dimensions [width x height x depth mm]					
With mounting brackets	35 x 210 x 174.7				45 x 210 x 189.7
Without mounting brackets and rotary switch	35 x 180 x 165				45 x 180 x 180
Cooling method	Heat sink				Fan cooling
Maximum motor cable length [m]					
EMC Compliance Category C2	n.a.	n.a.	n.a.	n.a.	n.a.
EMC Compliance Category C3	30	30	30	30	30
Without EMC Compliance	50	50	50	50	50

A 3 General specifications



Control accuracy may vary depending on the environment, application conditions or different motors.

Control characteristics	Control Method	V/F (linear / square)
	Applicable motor	3-phase asynchronous motor
	Starting torque *	150 % / 3 Hz
	Speed control range *	1: 50 (V/F control for asynchronous motor, heavy duty, rated)
	Carrier frequency	4 kHz, 8 kHz, 16 kHz, AUTO (default: 4 kHz)
	Overload capability	150% of rated output current for 60 s and 180 % of rated current for 3 s Tripping at 300 % output current immediately
Protection characteristics	Motor protection	Over-current, over-voltage, over-heating, phase loss, ground fault, low voltage
Certifications	UL, TÜV For the latest certifications visit phoenixcontact.net/products	
Energy efficiency class	IEC/EN 61800-9-1	IE2

* Control accuracy may vary depending on the environment, application conditions or different motors

Table A-1 Output voltage (24VOUT)

Rated output voltage [V]	24
Supply output range [V]	22 ... 27
Maximum supply output current [mA]	100

Table A-2 Digital input (SPEED1, SPEED2, RESET)

Rated control voltage [V]	24
Type of input voltage	DC
Typical control current [mA]	6
Delay time [ms]	0.7
Timing RESET terminal [ms]	500 ... 3000

Table A-3 PTC (TH1/TH2)

Rated output voltage [V]	10
Maximum supply output current [mA]	15
PTC range [V]	
PTC over-temperature	8,43
PTC short circuit detection threshold	9,99
PTC open circuit detection threshold	2,5

Table A-4 Digital input (STO+ / STO-)

Rated STO voltage [V]	24
Type of input voltage	DC
STO voltage range [V]	
Minimum permissible voltage	-3
Maximum permissible voltage	30
Voltage low level @ $I < 0.5 \text{ mA}$	15
Voltage low level @ $0.5 \text{ mA DC} \leq I \leq 15 \text{ mA DC}$	5
Voltage high level @ $I \geq 2 \text{ mA DC}$	15
Control current [mA]	15
Reaction time [ms]	20
Light test [ms]	
Maximum pulse duration	8
Maximum cycle time ($x \cdot$ pulse duration)	100
Dark test [ms]	
Maximum pulse duration	3
Maximum cycle time ($x \cdot$ pulse duration)	100

Table A-5 Relay output (12 (NO) / 11 (COM) / 14 (NC))

Type of input voltage	AC / DC
Relay voltage [V]	
Maximum DC voltage	30
Maximum AC voltage	125
Relay current [A]	
Maximum DC current	3
Minimum DC current @ 5 V DC	0.01
Maximum AC current	3

A 4 Environment for operation, storage and transportation



NOTE:

This is a product for environment 1 (industry). The device can cause unwanted radio interference if used in Class 2 environments (household). In this case, the user may be obligated to take the necessary precautionary measures.



Do not expose the CONTACTRON Speed Starter to a poor environment, such as one with dust, direct sunlight, corrosive/ inflammable gases, humidity, liquids, or excessive vibration. The salt in the air must be less than 0.01 mg/cm² every year.

Environment	Installation location	IEC 60364-1/ IEC 60664-1	Pollution degree 2 Overvoltage category III Indoor use only
	Degree of protection	IP20 / UL Open Type / NEMA 250 Type 1	
	Surrounding temperature	Operation	-20 °C ... 55 °C without current derating 55°C ... 60 °C with linear current derating
		Storage	-25 °C ... 85 °C
		Transportation	-25 °C ... 85 °C
	Rated humidity	Non-condensing, non-freezing	
		Operation	Maximum 90 %
		Storage / transportation	Maximum 95 %
	No water condensation		
	Air pressure	Operation	86 kPa ... 106 kPa
		Storage/ transportation	70 kPa ... 1106 kPa
	Pollution level	IEC 60721-3	
		Operation	Class 3C2, Class 3S2
		Transportation	Class 2C2, Class 2S2
		Storage	Class 1C2, Class 1S2
	Concentrate prohibited		
	Altitude	<2000 m (for altitudes >1000 m, de-rate to use it.) Table A-8 on page 129	
Package drop	Storage	ISTA procedure 1A (according to weight) IEC 60068-2-31	
	Transportation		
Vibration	Operating	0.075 mm / 1G	
	Non-operating	Compliance with IEC 60068-2-6	

CONTACTRON Speed Starter

Shock	Operating	15G, 11 ms
	Non-operating	Compliance with IEC/EN 60068-2-27
EMC	Standard requirements	IEC/EN 61800-3
	Requirements for functional safety	IEC/EN 61800-5-2 (second environment)

A 5 Derating for altitude and carrier frequency

A 5.1 Derating curve for altitude

Figure A-1 Altitude derating curve

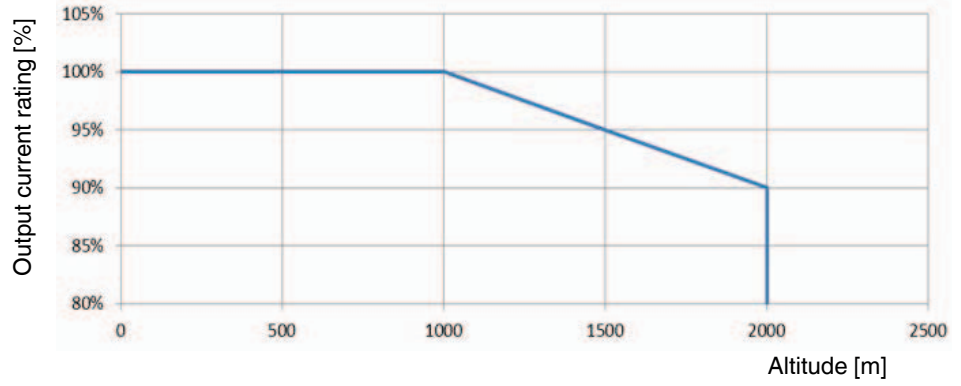

A 5.2 Derating curve for carrier frequency

Figure A-2 230 V models

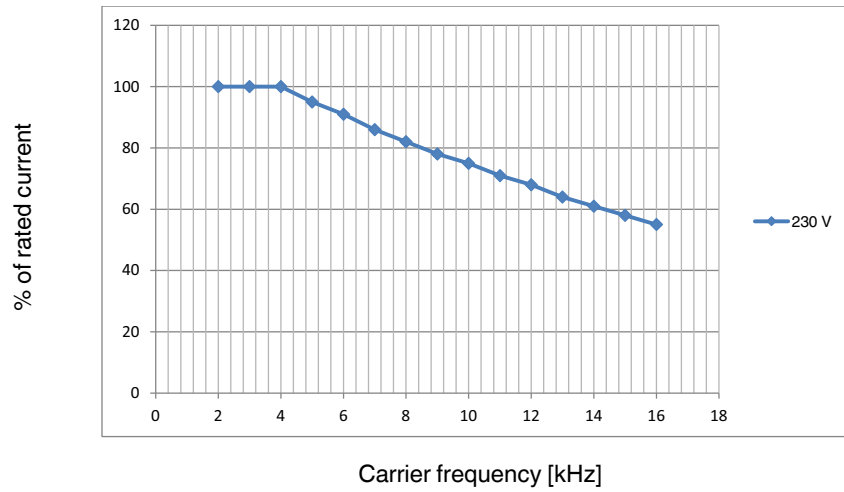

Table A-6 Rated output current [%] of 230 V models for different carrier frequencies

Frequency [kHz]	4	8	16
Rated output current [%]	100	82	55

Figure A-3 480 V models

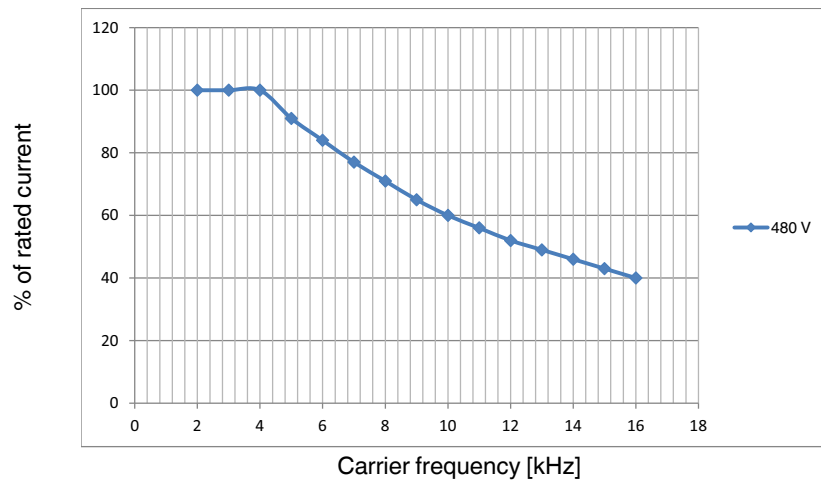

Table A-7 Rated output current [%] of 480 V models for different carrier frequencies

Frequency [kHz]	4	8	16
Rated output current [%]	100	71	40

A 6 Operational limits

Table A-8 Operational limits

Characteristic	Operating environment
Operating temperature	If the CONTACTRON Speed Starter operates at the rated current, the ambient temperature needs to be between -20 °C ... 55 °C. If the temperature is above 55 °C, decrease 2.5 % of the rated current for every 1 °C increase in temperature. The maximum allowable temperature is 60 °C.
Maximum altitude	If the CONTACTRON Speed Starter is installed at an altitude of 0 m ... 1000 m, follow normal operation restrictions. For altitudes of 1000 m ... 2000 m, decrease the Speed Starter's rated current by 1 % or lower the temperature by 0.5 °C for every 100 m increase in altitude. If installing at an altitude higher than 2000 m is required, contact Phoenix Contact for more information.
Impulse voltage insulation	6 kV Safe mains isolation by double / reinforced insulation between power electronic and control electronic (IEC/EN 61800-5-1)
Leakage current	>3.5 mA AC, >10 mA DC (IEC/EN 61800-5-1)

A 7 Applicable standards

EMC Directive 2014/30/EU is considered by compliance with and proof of the following product standard:

IEC/EN 61800-3	Adjustable speed electrical power drive systems - Part 3: EMC requirements including specific requirements for test method
----------------	--

RoHS Directive 2011/65/EU is considered by compliance with and proof of the following standard:











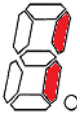





















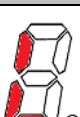

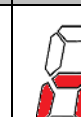

EN 50581	Technical documentation for the assessment of electrical and electronic products with respect to the restriction of hazardous substances
----------	--

Machinery Directive 2006/42/EU is considered by compliance with and proof of the following harmonized standards:

IEC/EN 61800-5-2:	Adjustable speed electrical power drive systems – part 5-2: Safety requirements – Functional Safety
IEC/EN 61800-5-1 + A1	Adjustable speed electrical power drive systems - Part 5-1 Safety requirements - Electrical, thermal and energy requirements
EN ISO 13849-1	Safety of Machinery – Safety-related parts of control systems – Part 1: General principles for design
EN 62061:2005 + A1 + A2	Safety of Machinery – Functional Safety of safety-related electrical, electronic and programmable electronic control systems
IEC 61508-1 to 7	Functional Safety of electrical, electronic and programmable electronic safety-related systems – Part 1 to 7

B Reference table for the seven-segment digital control panel LED display

Table B-1 Reference table for the seven-segment digital control panel LED display

Digit	0	1	2	3	4	5	6	7	8	9
Display										
Digit	A	a	B	b	C	c	D	d	E	e
Display		-	-				-			-
Digit	F	f	G	g	H	h	I	i	J	j
Display		-		-				-		-
Digit	K	k	L	l	M	m	N	n	O	o
Display		-		-		-	-		-	
Digit	P	p	Q	q	R	r	S	s	T	t
Display		-	-		-			-	-	
Digit	U	u	V	v	W	w	X	x	Y	y
Display		-		-		-		-		-
Digit	Z	z								
Display		-								

C Appendixes

C 1 List of figures

Section 1

Figure 1-1:	Reverse running	13
-------------	-----------------------	----

Section 2

Figure 2-1:	Model overview	15
Figure 2-2:	1-phase device	16

Section 3

Figure 3-1:	Frame A1: CSS 0.25-1/3, CSS 0.25-3/3, CSS 0.37-1/3, CSS 0.37-3/3, CSS 0.55-3/3	19
Figure 3-2:	Frame A2: CSS 0.25-1/3-EMC, CSS 0.25-3/3-EMC, CSS 0.37-1/3-EMC, CSS 0.37-3/3-EMC, CSS 0.55-3/3-EMC, CSS 0.75-3/3-EMC	20
Figure 3-3:	Frame B1: CSS 1.5-1/3, CSS 1.5-3/3	21
Figure 3-4:	Frame B1: CSS 0.55-1/3, CSS 0.75-1/3, CSS 0.75-3/3	22
Figure 3-5:	Frame B2: CSS 0.55-1/3-EMC, CSS 0.75-1/3-EMC, CSS 1.5-1/3-EMC, CSS 1.5-3/3-EMC	23

Section 4

Figure 4-1:	Airflow single installation	26
Figure 4-2:	Airflow side-by-side horizontal installation / zero stacking installation / side-mounting installation	26
Figure 4-3:	Derating curve	27
Figure 4-4:	Single / side-by-side horizontal / zero stack installation	28
Figure 4-5:	Side-mounting Installation	28
Figure 4-6:	Dimensions	29

Section 5

Figure 5-1:	Power terminals	31
Figure 5-2:	Control terminals	32
Figure 5-3:	PE terminal	34
Figure 5-4:	Wiring diagram	35
Figure 5-5:	Input: 1-phase power	36
Figure 5-6:	Input: 3-phase power	37
Figure 5-7:	Wrong wiring setup for ground wires	40
Figure 5-8:	Correct wiring setup for ground wires	40
Figure 5-9:	Symmetrical grounding power system	41
Figure 5-10:	Grounding at a corner in a triangle configuration	42
Figure 5-11:	Grounding at a midpoint in a polygonal configuration	42
Figure 5-12:	Grounding at one end in a single-phase configuration	43
Figure 5-13:	No stable neutral grounding in a three -phase autotransformer configuration	43

Section 6

Figure 6-1:	Input: 1-phase power	47
Figure 6-2:	Input: 3-phase power	47

Section 8

Figure 8-1:	Fan kit EM-CSS-FAN-35 (art.-no. 1276911)	59
Figure 8-2:	Fan kit EM-CSS-FAN-45 (art.-no. 1276912)	59
Figure 8-3:	Fan removal	60
Figure 8-4:	Fan installation	60

Section 9

Figure 9-1:	Control panel	61
Figure 9-2:	Status display	65

Section 10

Figure 10-1:	Tripping curve	73
Figure 10-2:	Acceleration and deceleration time	74
Figure 10-3:	Displayed digits	75
Figure 10-4:	230 V series derating curve (1-phase input)	80
Figure 10-5:	480 V series derating curve (3-phase input)	80
Figure 10-6:	Example identity code	85

Section 12

Figure 12-1:	Overload capacity	95
--------------	-------------------------	----

Section 14

Figure 14-1:	Safe shutdown 2-channel	109
Figure 14-2:	Safe shutdown 1-channel (STO+)	110
Figure 14-3:	Safe shutdown 1-channel (STO-)	111

Appendix A

Figure A-1:	Altitude derating curve	127
Figure A-2:	230 V models	128
Figure A-3:	480 V models	129

C 2 List of tables

Section 3

Table 3-1:	Dimensions frame A1 (unit: mm [inch])	19
Table 3-2:	Dimensions frame A2 (unit: mm [inch])	20
Table 3-3:	Frame B1 with fan (unit: mm [inch])	21
Table 3-4:	Frame B1 with heat sink (unit: mm [inch])	22
Table 3-5:	Frame B2 (unit: mm [inch])	23

Section 4

Table 4-1:	Airflow direction	26
Table 4-2:	Minimum mounting clearances	27

Section 5

Table 5-1:	Terminal description	32
Table 5-2:	Maximum motor cable length at 4 kHz carrier frequency (1-phase)	44
Table 5-3:	Maximum motor cable length at 4 kHz carrier frequency (3-phase)	45

Section 7

Table 7-1:	Protection with standard fuses (IEC)	49
Table 7-2:	Standard fuses with SCCR (UL and cUL)	50
Table 7-3:	Circuit breakers with SCCR (UL and cUL)	52

Section 8

Table 8-1:	Accessories	53
------------	-------------------	----

Section 9

Table 9-1:	Descriptions of functions	61
Table 9-2:	Status description	65
Table 9-3:	Options and their description	70
Table 9-4:	Status overview	72

Section 13

Table 13-1:	System conditions	105
Table 13-2:	Safety parameters for EN ISO 13849-1	105
Table 13-3:	Safety parameters for IEC 61508, Part 1-7 and IEC/EN 62061 - high demand	105

Appendix A

Table A-1:	Output voltage (24VOUT)	123
Table A-2:	Digital input (SPEED1, SPEED2, RESET)	123
Table A-3:	PTC (TH1/TH2)	124
Table A-4:	Digital input (STO+ / STO-)	124
Table A-5:	Relay output (12 (NO) / 11 (COM) / 14 (NC))	124
Table A-6:	Rated output current [%] of 230 V models for different carrier frequencies	128
Table A-7:	Rated output current [%] of 480 V models for different carrier frequencies	129
Table A-8:	Operational limits	129

Appendix B

Table B-1:	Reference table for the seven-segment digital control panel LED display	131
------------	---	-----

C 3 Explanation of terms

CSS	CONTACTRON Speed Starter
ELCB	Earth Leakage Circuit Breaker
EMC	Electromagnetic Compatibility
HF	High frequency
IGBT	Insulated Gate Bipolar Transistor
IT jumper	Some components have a ground potential when the IT jumper is not removed. Monitoring devices of an IT system will detect this. Moreover, an over-voltage of components might occur in an IT system. If the CONTACTRON Speed Starter is connected to an IT grid, the IT jumper has to be removed.
I-C	Inductance-Capacitance
R-C	Resistance-Capacitance
LED	Light Emitting Diode
MCCB	Molded Case Circuit Breaker
PE	Protected Earth
PELV	Protective Extra-Low Voltage
PL	Performance Level
PTC	Positive Temperature Coefficient
PWM	Pulse Width Modulation
RCD	Residual Current Device
RFI	Radio Frequency Interference
SELV	Safety Extra-Low Voltage
SIL	Safety Integrity Level
STO	Safe Torque Off

C 4 Index

Numerics

1. rF - motor rated frequency	77
10. PL - parameter lock	84
11. res - parameter reset	84
12. ID - identity code	85
13. ver - firmware version	85
14. FC - feedback contact	85
2. rv - motor rated voltage	78
230 V models	
cable length	44, 45
derating curve	128
3. oF - highest output frequency	78
4. PF - pulse frequency	79
480 V models	
derating curve	129
5. vF - vF wave form	81
6. bo - start boost	81
7. vL - voltage lift	81
8. Sc - slip compensation	82
9. PTC - PTC active	83

A

Airflow

side-by-side horizontal installation	26
side-mounting installation	26
single installation	26
zero stacking installation	26

Application example

1-phase	107
3-phase	108

Asymmetric ground system

corner in a triangle configuration	42
midpoint in a polygonal configuration	42
no stable neutral grounding in a three-phase autotransformer configuration	43
one end in a single-phase configuration	43

B

Block diagram

1-phase	112
3-phase	113

C

Cable length	44
230 V models	44, 45
leakage current	44
surge voltage	44
Cable tie for EMC shielding plate	53
cF2	101
CF3	101
Circuit breakers	
UL and cUL	52
Circuit diagram	
1-phase	112
3-phase	113
Control terminals	
description	32
Corner grounded TN system	42
CURRENT	
parameters	73
setting	63

D

Derating curve

230 V models	128
480 V models	129
ambient	127

Dimensions

DIN rail	29
frame A1	19
frame A2	20
frame B1 with fan	21
frame B1 with heat sink	22
frame B2	23

DIN rail

dimensions	29
installing CSS	29
removing CSS	30

E

EEPROM read error	101
EMC shielding plate	53
accessories	53
cable tie	53
installation	55

Error codes

EEPROM read error	101
ground fault	100
hardware check	101
IGBT over heating	97
IGBT temperature detection failure.....	98
motor overload	94
output phase loss	101
over current SPEED1	96
over current SPEED2	96
over temperature	98
over voltage.....	93
overload SPEED1	94
overload SPEED2	94
phase loss protection	91
phase UV short.....	100
phase UW short.....	100
phase VW short.....	101
power component overload	97
PTC open	99
PTC short circuit.....	99
under voltage.....	92

F

Factory reset	84
Fan.....	58
installation	60
models.....	58
removal	60
Feedback contact	85
Firmware version.....	85
Floating ground system.....	41
Frame A1	
dimensions	19
Frame A2	
dimensions	20
Frame B1	
dimensions	21
Frame B1 with fan dimensions	21
Frame B1 with heat sink dimensions.....	22
Frame B2	
dimensions	23
Fuses	
IEC	49
UL and cUL	50

G

GFF.....	100
Ground fault error.....	100
Ground system	
asymmetric.....	42
floating	41
symmetric.....	41
Grounding	
correct wiring.....	40
wrong wiring	40

H

Hardware check error	101
Highest output frequency	78
Hot	97

I

I ² t 1	94
I ² t 2	94
Identity code	85
IGBT over heating error.....	97
IGBT temperature detection failure error.....	98
Installing	
CSS on DIN rail	29
EMC shielding plate	55
fan	60
IoSP1	96
IoSP2	96
IT jumper.....	38
function	38
IT system	41

L

Leakage current	44
-----------------------	----

M

Main circuit diagram	
1-phase	47
3-phase	47
Model name	17
Motor overload error	94
Motor rated frequency.....	77
Motor rated voltage	78
Mounting clearances.....	27

N	
Nameplate	16
Naming conventions	17
O	
oL3	97
oLSP1	94
oLSP2	94
OPTIONS	
parameters	77
setting	69
OPTIONS parameters	
factory reset	84
firmware version	85
highest output frequency	78
identity code	85
motor rated frequency	77
motor rated voltage	78
parameter lock	84
PTC	83
pulse frequency	79
relay output	85
slip compensation	82
start boost	81
V/F-waveform	81
voltage lift	81
ot	98
OutPL	101
Output phase loss error	101
ov	93
Over current SPEED1 error	96
Over current SPEED2 error	96
Over temperature error	98
Over temperature warning	89
Over voltage error	93
Over voltage warning	88
Overload SPEED1 error	94
Overload SPEED2 error	94
P	
Parameter lock	84
Phase loss protection error	91
Phase UV short error	100
Phase UW short error	100
Phase VW short error	101
PHL	
91	
Power component overload error	
97	
PTC	
83	
PTC open error	
99	
PTC short circuit error	
99	
PTCO	
99	
PTCSC	
99	
Pulse frequency	
79	
R	
RAMP	
parameters	74
setting	64
Relay output	
85	
Removing	
CSS from DIN rail	30
fan	60
RFI jumper	39
RFI jumper	
removal	39
Rotary switch	
61	
CURRENT	63, 73
OPTION	69, 77
RAMP	64, 74
SPEED1	76
SPEED1 when RUNNING	67
SPEED1 when STOP	66
STATUS	65, 75
S	
Safe torque off	
applicable standards	103
function description	103
Safe torque off warning	
88	
Seven segment display	
131	
Slip compensation	
82	
SPEED	
parameters	76
setting	66
Standards	
130	
Start boost	
81	
STATUS	
parameters	75
setting	65
Surge voltage	
44	
Symmetric ground system	
41	

T

Technical data

230 V models 1-phase with EMC filter.....	117
230 V models 1-phase without EMC filter.....	115
480 V models 3-phase with EMC filter.....	121
480 V models 3-phase without EMC filter.....	119
environmental data.....	125
general specifications.....	123

Terminals

control.....	32
main circuit.....	47
power.....	31

tH1o.....	98
-----------	----

U

Under voltage error.....	92
Under voltage warning.....	87
U-V.....	100
UV.....	92
U-W.....	100

V

V/F-waveform.....	81
Voltage lift.....	81
V-W.....	101

W

Warnings

over temperature.....	89
over voltage.....	88
safe torque off.....	88
STO.....	88
under voltage.....	87

Wiring

connection possibilities.....	36
control terminals.....	31, 32
power terminals.....	31
system.....	35

Please observe the following notes

General Terms and Conditions of use for technical documentation

Phoenix Contact reserves the right to alter, correct, and/or improve the technical documentation and the products described in the technical documentation at its own discretion and without giving prior notice, insofar as this is reasonable for the user. The same applies to any technical changes that serve the purpose of technical progress.

The receipt of technical documentation (in particular user documentation) does not constitute any further duty on the part of Phoenix Contact to furnish information on modifications to products and/or technical documentation. You are responsible to verify the suitability and intended use of the products in your specific application, in particular with regard to observing the applicable standards and regulations. All information made available in the technical data is supplied without any accompanying guarantee, whether expressly mentioned, implied or tacitly assumed.

In general, the provisions of the current general Terms and Conditions of Phoenix Contact apply exclusively, in particular as concerns any warranty liability.

This manual, including all illustrations contained herein, is copyright protected. Any changes to the contents or the publication of extracts of this document are prohibited.

Phoenix Contact reserves the right to register its own intellectual property rights for the product identifications of Phoenix Contact products that are used here. Registration of such intellectual property rights by third parties is prohibited.

Other product identifications may be afforded legal protection, even where they may not be indicated as such.

How to contact us

Internet

Up-to-date information on Phoenix Contact products and our Terms and Conditions can be found on the Internet at:

phoenixcontact.com

Make sure you always use the latest documentation.

It can be downloaded at:

phoenixcontact.net/products

Subsidiaries

If there are any problems that cannot be solved using the documentation, please contact your Phoenix Contact subsidiary.

Subsidiary contact information is available at phoenixcontact.com.

Published by

PHOENIX CONTACT GmbH & Co. KG

Flachsmarktstraße 8

32825 Blomberg

GERMANY

Should you have any suggestions or recommendations for improvement of the contents and layout of our manuals, please send your comments to:

tecdoc@phoenixcontact.com

PHOENIX CONTACT GmbH & Co. KG
Flachmarktstraße 8
32825 Blomberg, Germany
Phone: +49 5235 3-00
Fax: +49 5235 3-41200
E-mail: info@phoenixcontact.com
phoenixcontact.com

© PHOENIX CONTACT 2021-09-02

109908_en_00
Order No. —00