

PSD-S CE-SM SCREW

Connection element with screw connection terminal blocks for base mounting

Data sheet
7959_en_02

© PHOENIX CONTACT 2015-05-04



1 Description

This connection element is provided as a component of a modular signal tower and facilitates the electrical connection of the signal tower.

According to your requirements, a signal tower may comprise any combination of up to five signal elements. You may use up to five optical signal elements or up to four optical and one audible signal element.

An audible signal element can be used as top element only.

A bayonet locking system establishes the mechanical and electrical connection between the elements.

Mounting elements for base or tube mounting can be used to mount the signal tower.

Features

- Connection element for the assembly on a mounting surface (base), an outlet box or an angle (see accessories)
- Screw terminal block connection
- Degree of protection: IP65, when mounted



Make sure you always use the latest documentation.
It can be downloaded from the product at phoenixcontact.net/products.

2	Table of contents	
1	Description	1
2	Table of contents	2
3	Ordering data	3
4	Technical data	3
5	Mounting the connection element.....	4
6	Connecting the cables	5
7	Example of a signal tower	5
8	Assembly notes for a signal tower	5

3 Ordering data

Description	Type	Order No.	Pcs./Pkt.
Connection element with screw connection terminal blocks for base mounting	PSD-S CE-SM SCREW	2700093	1

Accessories	Type	Order No.	Pcs./Pkt.
Outlet box with lateral cable entry for floor and base mounting	PSD-S ME OB	2700153	1
Angle for floor mounting, black	PSD-S ME BR-SM	2700144	1
Angle for single-sided floor mounting, concealed cable routing, black	PSD-S ME BR-SM/1S	2700160	1
Angle for two-sided floor mounting, concealed cable routing, black	PSD-S ME BR-SM/2S	2700161	1

4 Technical data

Dimensions (in mm)

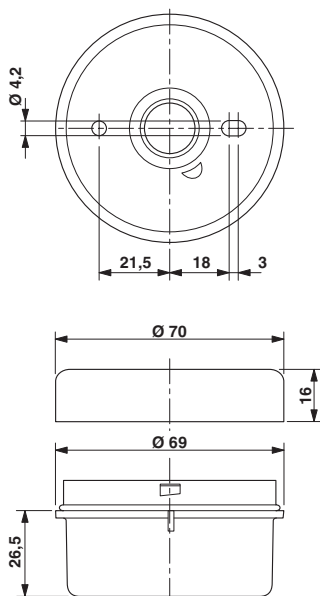

Diameter	69 mm
Height	27 mm

General data

Material	PA-GF
Color	black
Weight	83 g
Ambient temperature (operation)	-30 °C ... 50 °C
Degree of protection	IP65, when installed
Mounting position	any
Mounting type	Base mounting

General data

Connection	Rubber seal pre-installed for each element
Number of mountable signal elements	max. 5
Scope of delivery	End cover and seal

Connection data (without ferrule)

Connection method	Screw connection
Conductor cross section, stranded	0.5 mm ² ... 1.5 mm ²
Conductor cross section, stranded [AWG]	20 - 15
Stripping length	7 mm

Connection data (With ferrule)

Connection method	Screw connection
Conductor cross section, stranded	0.25 mm ² ... 1.5 mm ²
Conductor cross section, stranded [AWG]	23 - 15
Stripping length	7 mm

Connection data (solid)

Connection method	Screw connection
Conductor cross section, solid	0.5 mm ² ... 1.5 mm ²
Conductor cross section, solid [AWG]	20 - 15
Stripping length	7 mm

Approvals / conformities

Conformance with EMC directive 2004/108/EC and for low-voltage directive 2006/95/EC

For the latest approvals, please visit phoenixcontact.net/products.

5 Mounting the connection element

Install the connection element directly on a flat mounting surface, on a contact box or an angle. The possible options are indicated in the ordering data under accessories.

For the mounting the connection element, proceed as described in the package slip.

For the connection of cables, proceed as described in the package slip.



Please refer to the package list for connection options. It is enclosed with the connection element and can be downloaded from the internet at phoenixcontact.net/products.

6 Connecting the cables



NOTE:
When working on the connection element, disconnect the power to the signal tower!

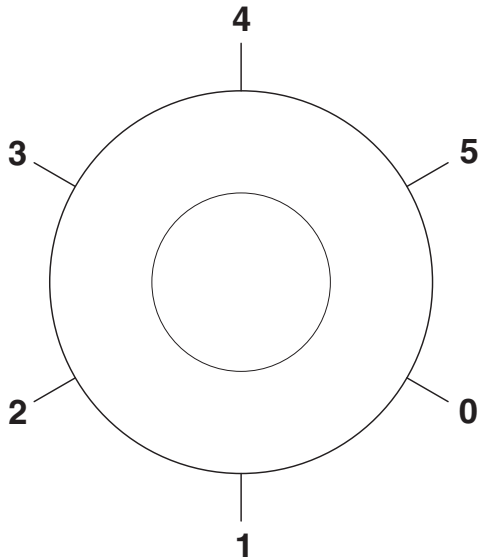

Figure 1 Connections in the connection element

Connection	Meaning
0	Reference potential (GND, N)
1	Control of the signal element 1
2	Control of the signal element 2
3	Control of the signal element 3
4	Control of the signal element 4
5	Control of the signal element 5



When using the audible elements "siren element, 7 tones..." or "voice output element", several control lines are needed for the audible element, as the case may be. In this case, please note the entries in the corresponding data sheet or in the package slip.

7 Example of a signal tower

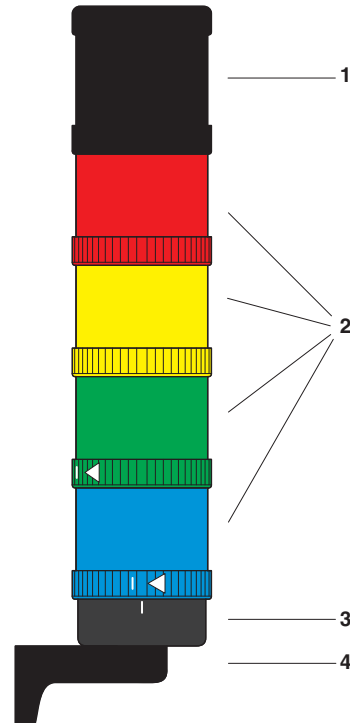

Figure 2 Example of a signal tower

Key:

- 1 Audible signal element
- 2 Optical signal element
- 3 Connection element
- 4 Assembly element

8 Assembly notes for a signal tower

- Only use a maximum of five elements within a signal tower.
- Use only one audible element in a signal tower and position this element on top.
- When connecting the bayonet locking, please note the markings (see "Assembly of the individual elements" in the data sheets of the signal elements).